

ZEXEL

FOREWORD

This service manual is to be used for service and maintenance of RFD (K) Type mechanical governors and describes the construction, operation and adjustment procedures for these governors for special-purpose vehicles (cranes, etc.).

A1

Foreword

Governor RFD (K)



FEATURES

The performance required of mechanical governors for special purpose vehicles differs from that required for ordinary vehicles such as buses and trucks, etc.

In other words, the same engine may be used at times for traveling and at other times for hoisting and lowering a crane; therefore, a distinction must be made between usage for traveling and usage for working.

This can easily be achieved by altering the function of the injection pump.

The RFD Type mechanical governor is provided with the functions required for each type of operation and can thus be used for ordinary travel (minimum-maximum speed operation) and stationary operation when the engine is used as an auxiliary power source (variable speed operation).

The RFD Type mechanical governor was developed based on the RAD governor (minimum-maximum speed) but with the addition of variable speed specifications.



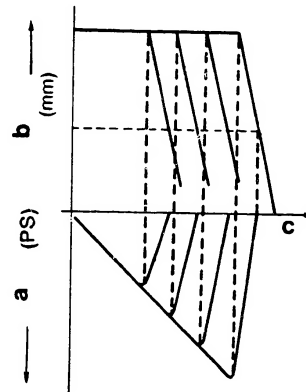
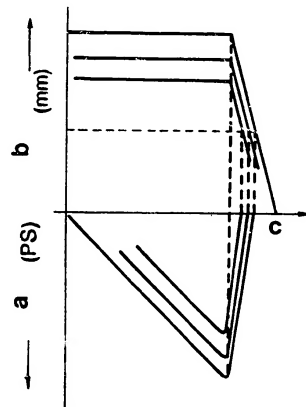
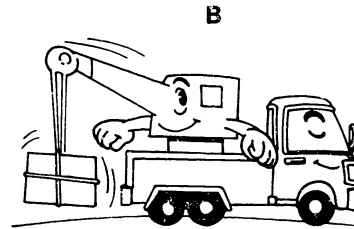
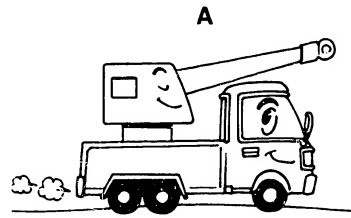

Fig. 1

A = When travelling (Minimum-maximum speed operation)

B = When working (Variable speed operation)

a = Output
 b = Control rack position
 c = Engine speed (rpm)

a = Output
 b = Control rack position
 c = Engine speed (rpm)

Fig. 1 shows the relationship between engine output characteristics and governor performance for both minimum-maximum speed governor and variable speed governor operation.

A3	Features	↔
	Governor RFD (K)	

A4	Features	↔
	Governor RFD (K)	

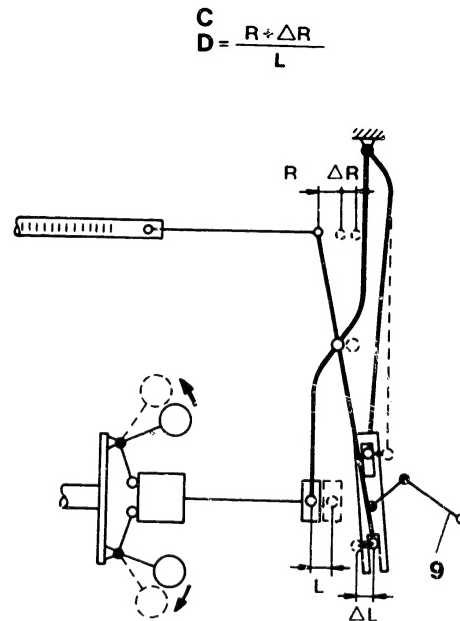
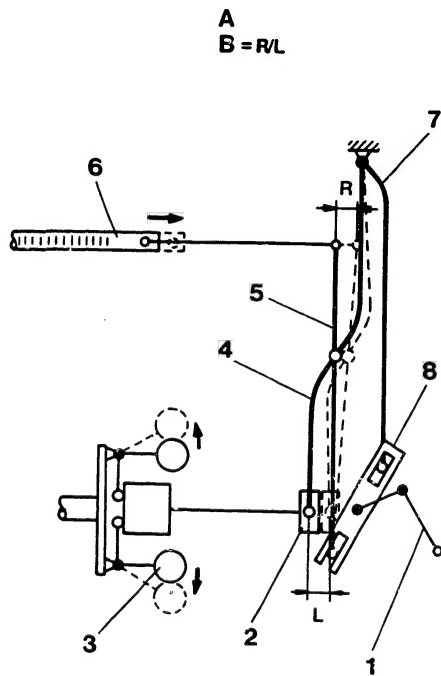

Fig. 2

A = Low-speed control
B = Lever ratio

C = High-speed control
D = Lever ratio

- 1 = Load control lever (idling position)
- 2 = Shifter
- 3 = Flyweight
- 4 = Guide lever
- 5 = Floating lever
- 6 = Control rack
- 7 = Tension lever
- 8 = Supporting lever
- 9 = Load control lever (full-load position)

A5

Features
Governor RFD (K)



A6

Features
RFD (K)



Like the RAD type governor, Z E X E L unique link mechanism makes it possible to change the floating lever ratio at low-speed and high-speed.

That is, during low-speed control, the floating lever ratio is decreased so the control rack can be moved even by the small amount of centrifugal force generated by the flyweight to obtain a stabilized speed.

During high-speed operation, the lever ratio is increased to improve governor control of speed fluctuations. Thus, any desired speed can be set without replacing the governor spring.



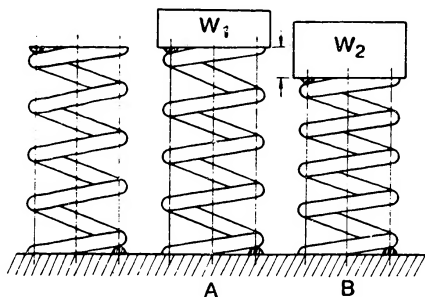

Fig. 3

PRINCIPLE OF OPERATION

Spring And Weight

If a weight (W_1) less than the spring force is placed on the spring, the spring will not be compressed : that is, its length remains the same (A).

If a weight (W_2) greater than the spring force is placed on the spring, the spring will be compressed to the position where the spring force is balanced with the weight (B).



Spring and weight (cont' d)

When the spring is compressed to support the weight it is said that the spring and weight are balanced.

Balance between spring and centrifugal force

The centrifugal force of the flyweights depends upon the number of revolutions. As the number of revolutions of the flyweights increase, the flyweights move outward from the solid-line state in the left hand figure, and the spring is compressed. Point A then moves to the right, and the centrifugal force and the spring force are balanced at the dotted-line positions.

If the number of revolutions of the flyweights decrease, the centrifugal force decreases, and the flyweights are brought inward by the spring force.



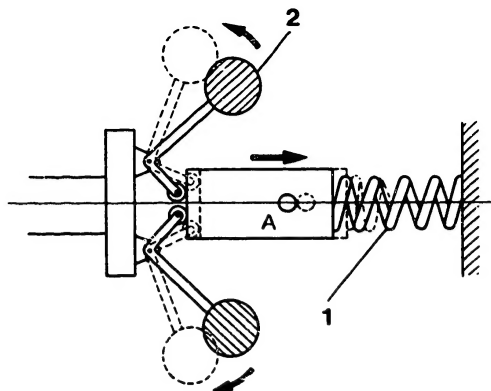

Fig. 4

1 = Spring
2 = Flyweight

Balance between spring and centrifugal force (cont' d)

Point A then moves to the left and stops at a position where the smaller centrifugal force and the spring force are balanced.

The mechanical governor controls the engine speed by utilizing the balance between the spring force and the flyweights' centrifugal force.

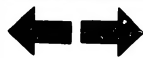

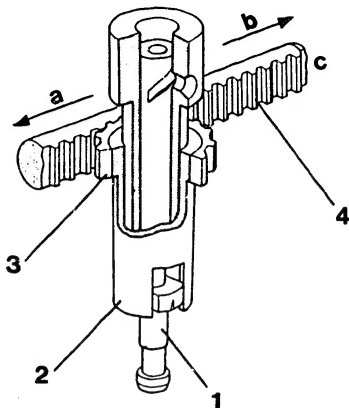

Fig. 5

1 = Plunger

2 = Control sleeve

3 = Pinion

4 = Control rack.

a = Fuel-increase direction

b = Fuel-decrease direction

c = Governor side

Fuel Injection Quantity Adjustment Operation

The injection pump controls the fuel injection quantity through the following operation.

The control rack rotates the pinion, and the control sleeve fixed to the pinion rotates the plunger.

The plunger is set in such a way that the fuel injection quantity decreases when the control rack is drawn toward the governor, and the fuel injection quantity increases when the control rack is moved in the opposite direction.



Fuel injection quantity adjustment operation

(Cont' d)

The governor is connected to the control rack to reduce the fuel injection quantity to the engine, and to prevent the engine speed from increasing, by moving the control rack in the fuel-decrease direction when the engine speed exceeds the specified value.

A12

Principle of operation

Governor RFD (K)



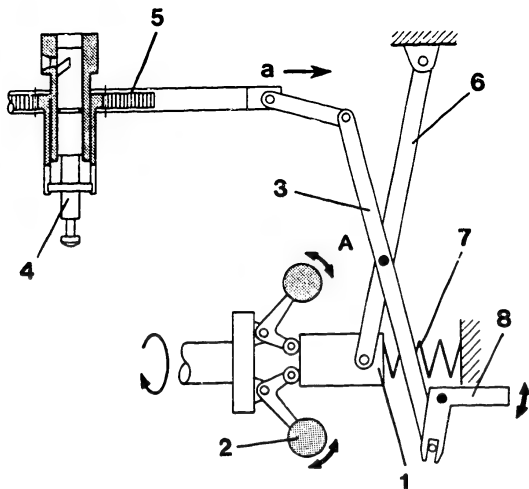

Fig. 6

- 1 = Shifter
- 2 = Flyweight
- 3 = Floating lever
- 4 = Plunger
- 5 = Control rack
- 6 = Guide lever
- 7 = Governor spring
- 8 = Load control lever

a = Fuel-decrease

● Minimum - Maximum Speed Governor

Fig. 6 shows a schematic diagram of the minimum-maximum speed governor's fuel injection quantity adjustment mechanism.



Minimum - maximum speed governor
(Cont' d)

The set force of the governor spring is fixed, and the control rack is moved directly by the load control lever (through the floating lever) to adjust the fuel injection quantity.

When engine speed increases and the flyweight's centrifugal force exceeds the set force of the governor spring, the shifter is moved to the right to compress the governor spring.

This movement in turn moves the floating lever (through the guide lever) to the right, and the fuel injection quantity is decreased.



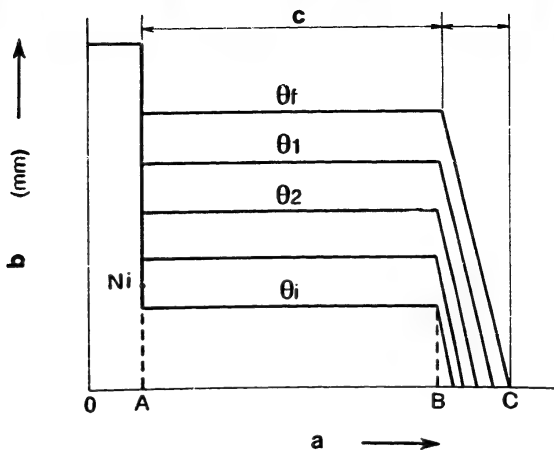

Fig. 7

- a = Pump speed (rpm)
- b = Control rack position
- c = Non-controlled zone

Figure 7 shows an example of the minimum-maximum speed governor's performance graph.

$\theta_f \sim \theta_i$ show the load control lever positions, and the control rack position for each load control lever position.

Because the set force of the governor spring is fixed, the speed at the beginning of governor control, that is B, has no relationship to control rack position, and is fixed.

Governor control occurs between $O \sim A$ (low speed range) and $B \sim C$ (high speed range).



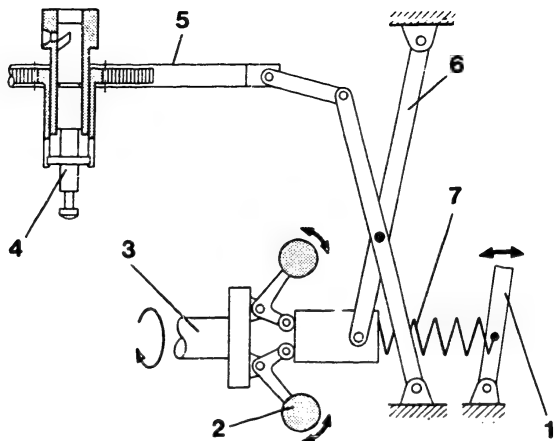

Fig. 8

- | | |
|-------------------------|---------------------|
| 1 = Speed control lever | 5 = Control rack |
| 2 = Flyweight | 6 = Guide lever |
| 3 = Shifter | 7 = Governor spring |
| 4 = Plunger | |

● Variable Speed Governor

Figure 8 shows a schematic diagram of the variable speed governor's fuel injection quantity adjustment mechanism.

Differing from the minimum-maximum speed governor, the set force of the variable speed governor's governor spring is varied by the speed control lever.



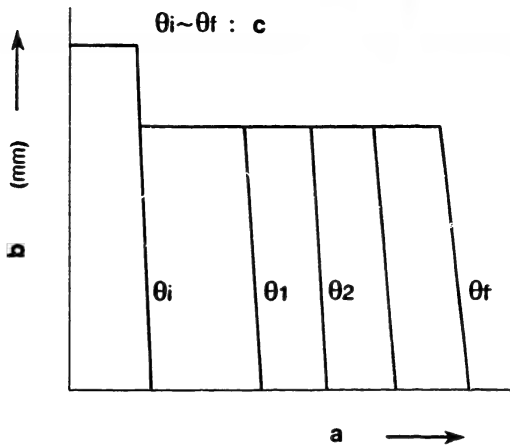

Fig. 9

- a = Pump speed (rpm)
- b = Control rack position
- c = Speed control lever position

Subsequently, as shown in Figure 9, the governor spring's set force changes between $\theta_i \sim \theta_f$ as the speed control lever position changes, and governor control occurs in all speed ranges.

As described above, the RFD governor has both a speed control lever and a load control lever, and, in accordance with the purpose for which it is used, can be utilized as both a minimum-maximum speed governor and variable speed governor.



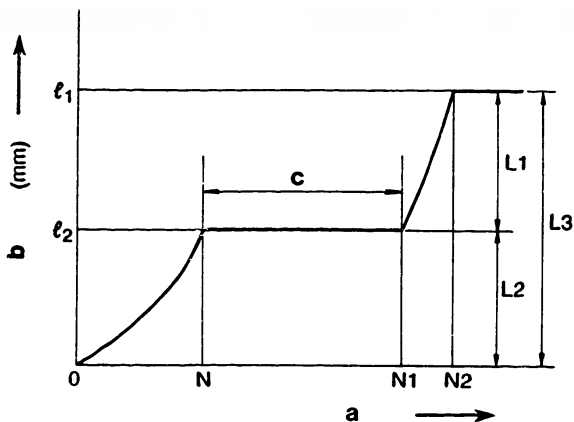

Fig. 10

- a = Pump speed (rpm)
- b = Flyweight lift
- c = Non-controlled zone

RFD Type Governor

Figure 10 shows the relationship between pump speed and flyweight lift.

A minimum-maximum speed governor balances the centrifugal force of the flyweight and the set force of the governor spring. It then returns the control rack in the fuel-decrease direction to prevent the speed from exceeding the allowable value and to maintain a stable idling speed. This governor is so named because it performs these two types of control.



When expressed as flyweight lift, this control operation is divided into two ranges: high-speed lift (L1) for high-speed control and low-speed lift (L2) for idling-speed control.

The combination of high-speed lift and low-speed lift equals the total flyweight lift (L3).

A19

Principle of operation

Governor RFD (K)



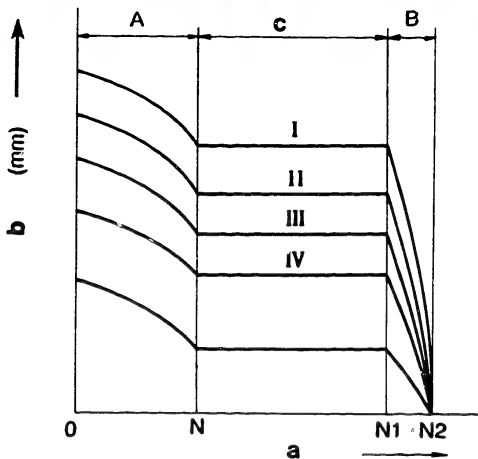

Fig. 11

- a = Pump speed (rpm)
- b = Control rack position
- c = Non-controlled zone

When the relationship between flyweight lift and pump speed is expressed in a governor performance graph (Figure 11), the low-speed control zone is represented by section A. The amount of control rack movement depends on the low-speed lift (L2), as shown in Figure 10.

The high-speed control zone is represented by section B with the amount of control rack movement depending on the high-speed lift (L1), as shown in Figure 10.

The section between A and B is usually referred to as the non-controlled zone, where there is no rack movement and no fluctuation of the flyweight lift, as shown in Figure 10, even though the speed varies.

Thus, when the operator directly operates the control lever (I, II, III in Figure 11), only the rack position is varied and the control output is effected.

For example, if the control lever is moved in the fuel-increase direction, the rack position changes from IV to III, II and then I in that order.

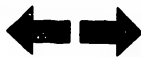

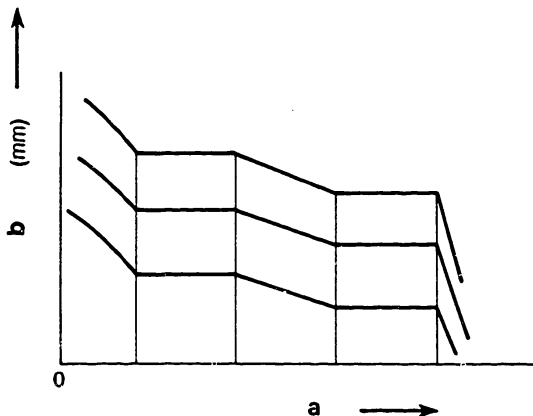

Fig. 12

a = Pump speed (rpm)
b = Control rack position

Figure 12 shows the governor performance graph of the RFD Type with a torque control spring.

Installation of the torque control spring has made it possible to move the control rack in the fuel-decrease direction in the zone where there is no governor control (this is called positive torque control).

Positive torque control is applied to pull the control rack in the fuel-decrease direction in the non-controlled zone, as engine speed increases, for the purpose of reducing the fuel injection quantity (refer to Fig. 12).



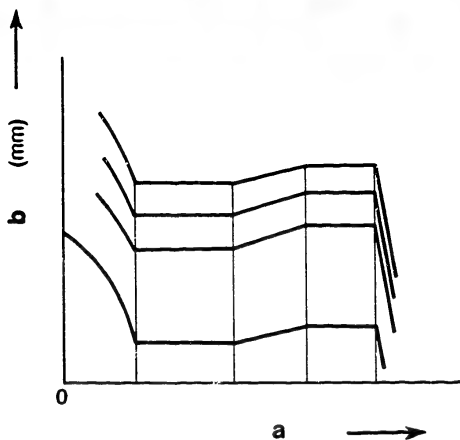

Fig. 13

a = Pump speed (rpm)
b = Control rack position

RFD-K Type Governor

The RFD and RFD-K Type governors differ in that the RFD-K Type is able to move the control rack in the fuel-increase direction in the governor's non-controlled zone while the RFD cannot.

That is, the control rack is moved in the fuel-increase direction in the non-controlled zone to increase the fuel injection quantity (this is called negative torque control; refer to Fig. 13).



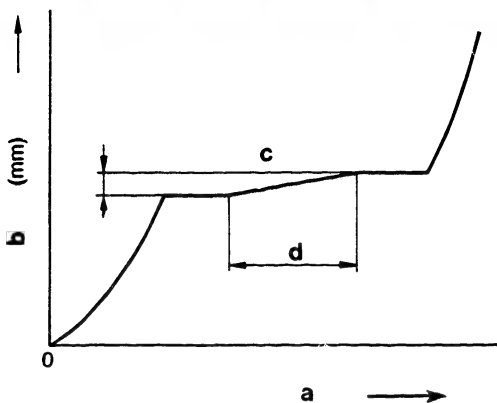

Fig. 14

- a = Pump speed (rpm)
- b = Flyweight lift
- c = Torque control stroke
- d = Torque control operating zone

A link mechanism utilizes the stroke of the torque control spring built into the tension lever, while an increase lever has been added to the guide lever.

In other words, the increase lever only moves the control rack in the fuel-increase direction an amount equal to the torque control stroke.



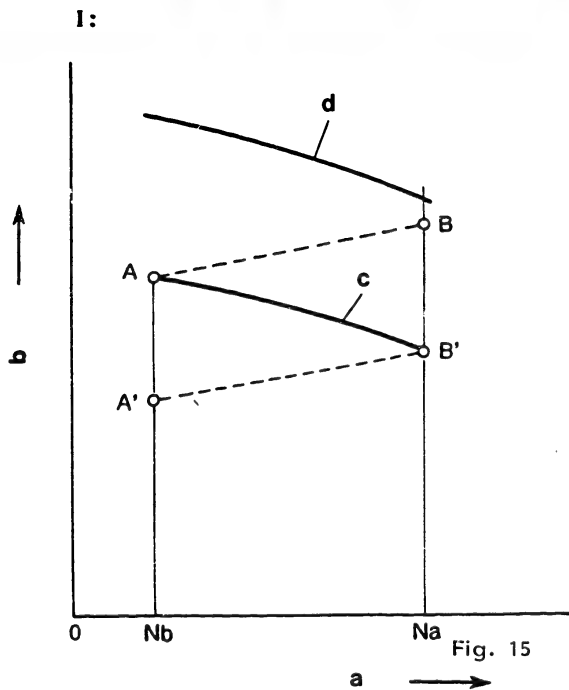

I: Relationship between pump speed and fuel injection quantity

a = Pump speed (rpm)
 b = Fuel injection quantity (cc/st)
 c = Engine demand curve
 d = Air intake

The Necessity for Positive Torque Control

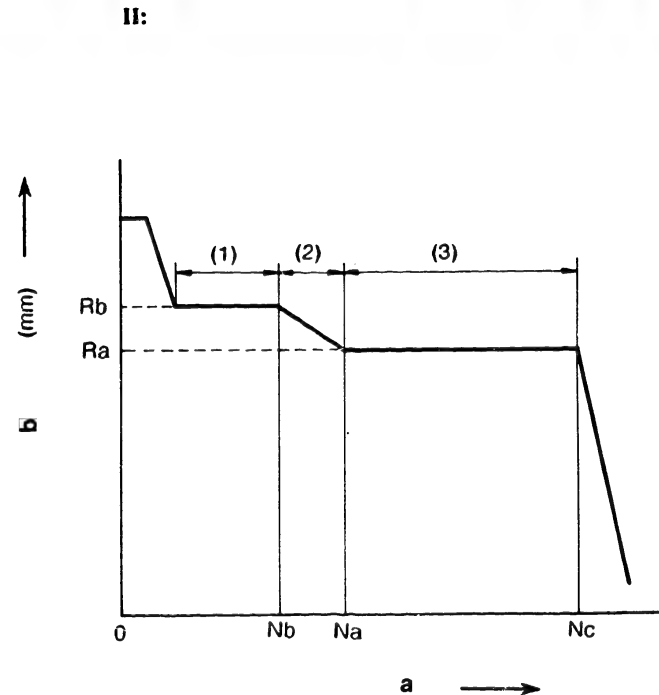

II: Relationship between pump speed and rack position

a = Pump speed (rpm)
 b = Control rack position

A25

Principle of operation
 Governor RFD (K)

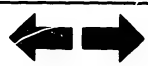

A26

Principle of operation
 Governor RFD (K)

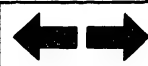

The air intake efficiency of the engine tends to decrease as the speed increases. However, for the same control rack position the fuel-injection quantity per stroke tends to increase as the speed of the injection pump increases. This is due to Pre-flow(*1) and After-flow(*2).

Consequently, if the full load fuel injection quantity is set at point A (Fig. 15) where sufficient output is obtained at low speed, the fuel injection quantity will increase (point B) as the speed increases, causing the engine to emit black smoke.

If the full load fuel injection quantity is set at point B, where no black smoke is emitted, the fuel injection quantity at low speed will be point A', resulting in insufficient output.

Positive torque control compensates for this by setting the fuel injection quantity to point A in the low-speed zone to obtain as much output as possible, and point B' in the high-speed zone.

This characteristic is required in precombustion chamber and eddy chamber type engines.

(*1) Pre-flow

The up stroke of the plunger creates pressure, which causes the fuel oil to start to flow before the plunger head covers the intake and exhaust ports in the plunger barrel.

(*2) After-flow

During the down stroke of the plunger, pressure causes the fuel oil to flow even when the lead has reached the intake and exhaust ports (end of injection).



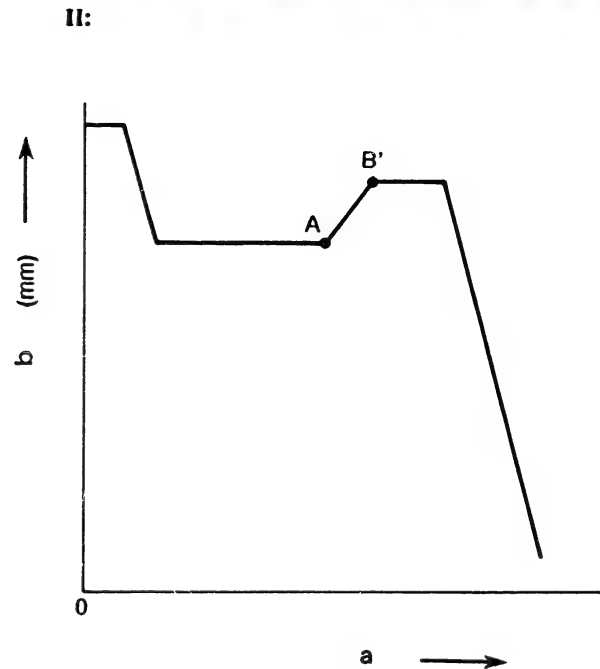
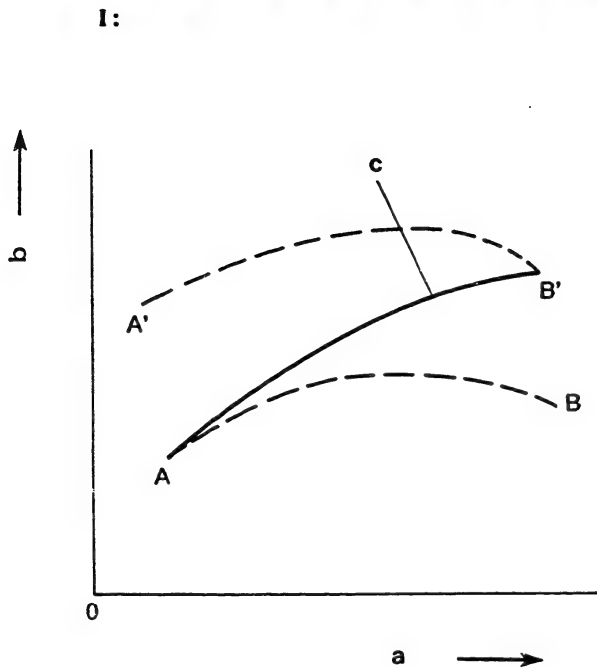

Fig. 16

I: Relationship between pump speed and fuel injection quantity

a = Pump speed (rpm)
 b = Fuel injection quantity (cc/st)
 c = Engine demand curve

II: Relationship between pump speed and rack position

a = Pump speed (rpm)
 b = Control rack position

The Necessity for Negative Torque Control

B1

Principle of operation
 Governor RFD (K)



B2

Principle of operation
 Governor RFD (K)

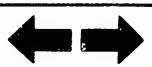

With pumps for direct-injection type engines, the fuel injection quantity tends to decrease at high speeds (as shown by the dotted lines in Figure 16), when engine speed increases for the same control rack position. This is due to Back-flow^(*).

Consequently, when the full load fuel injection quantity is set at point A to obtain sufficient power at low speeds, the fuel injection quantity in the high-speed zone is as shown by point B; therefore, there is insufficient power in the high-speed zone.

If the full load fuel injection quantity is set at point B', to obtain the required output, the fuel injection quantity in the low-speed zone will be point A', causing the emission of black smoke.

Negative torque control will act to increase the fuel injection quantity in the high-speed zone.

(*) Back-flow

Since the pressure inside the injection pipes of pumps for direct-injection type engines is high, the amount of returning fuel oil increases during the down stroke of the plunger, which tends to decrease the fuel injection quantity.



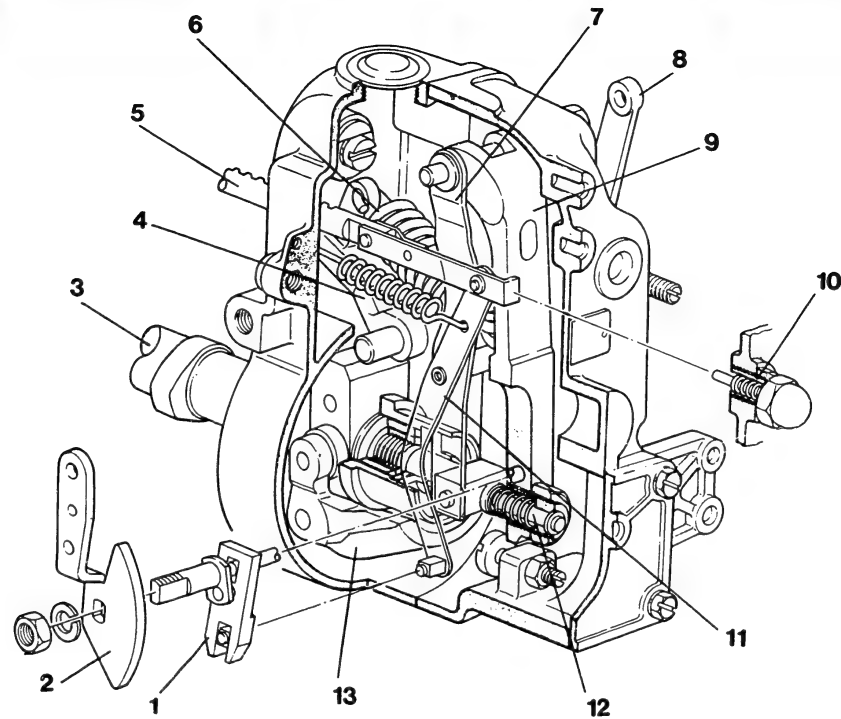

Fig. 17

RFD Type Governor

- 1 = Supporting lever
- 2 = Load control lever
- 3 = Camshaft
- 4 = Speed setting lever
- 5 = Control rack
- 6 = Governor spring
- 7 = Guide lever

- 8 = Speed control lever
- 9 = Tension lever
- 10 = Damper spring capsule
- 11 = Floating lever
- 12 = Idling spring capsule
- 13 = Flyweight assembly

CONSTRUCTION

B4	Construction	➔
	Governor RFD (K)	

B5	Construction	↔
	Governor RFD (K)	

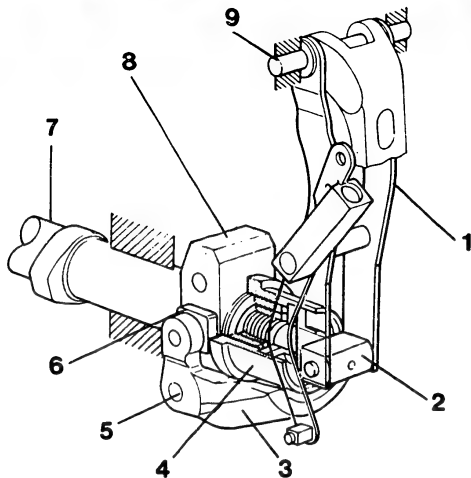

Fig. 18

- 1 = Guide lever
- 2 = Shifter
- 3 = Flyweight
- 4 = Sleeve
- 5 = Pin
- 6 = Slider
- 7 = Camshaft
- 8 = Flyweight holder
- 9 = Tension lever shaft

Thy flyweight assembly is mounted on the injection pump camshaft and turns together with the camshaft.

The flyweight opens and closes with the pressfitted pin in the flyweight holder acting as the fulcrum.



When the flyweight opens outward, the sleeve is pushed axially by the slider mounted on the tip of the flyweight arm.

The sleeve which contacts the flyweight slider is linked to the shifter by a snapping. This shifter is mounted on the guide lever, which is suspended from the tension lever shaft located in the top part of the governor cover.

B7

Construction

Governor RFD (K)



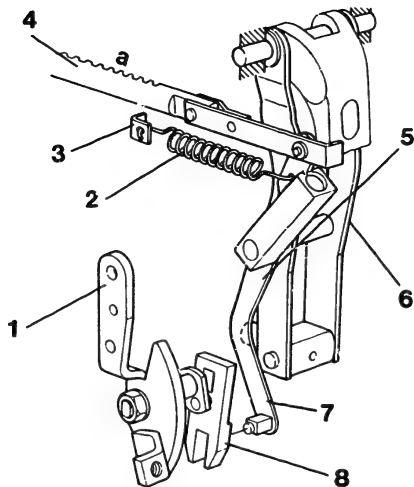

Fig. 19

- 1 = Load control lever
- 2 = Start spring
- 3 = Spring eye
- 4 = Control rack
- 5 = Floating lever
- 6 = Guide lever
- 7 = Eccentric shaft
- 8 = Supporting lever

a = Fuel-increase direction

A shaft in the center of the guide lever is the fulcrum for the floating lever. The top of the floating lever is connected to the control rack and the bottom fits in the bottom of the supporting lever.



The supporting lever is attached to the load control lever by an eccentric shaft. The floating lever can thus be moved freely by operating the load control lever.

The start spring is also attached to the top of the floating lever. The other end is attached to the spring eye in the governor housing. This spring acts to constantly move the control rack in the fuel-increase direction.

B9

Construction

Governor RFD (K)



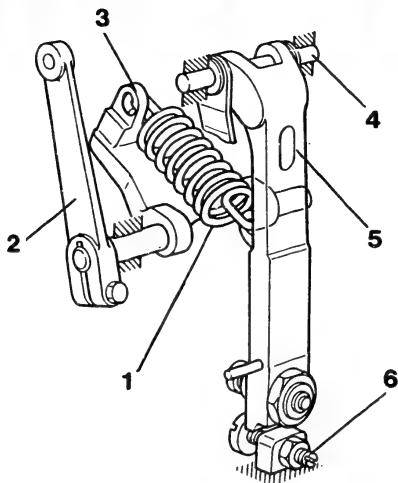

Fig. 20

- 1 = Governor spring
- 2 = Speed control lever
- 3 = Speed setting lever
- 4 = Tension lever shaft
- 5 = Tension lever
- 6 = Stroke adjusting screw

The tension lever is suspended from the tension lever shaft in the top part of the governor cover. A powerful governor spring is attached between the tension lever and speed setting lever.



This governor spring is tensioned by the speed control lever mounted on the speed setting lever shaft. Thus, in the normal speed range, the bottom end of the tension lever is forced against the stroke adjusting screw.

The force of the spring varies with the angle of the speed control lever; therefore, it is possible to set any desired maximum engine speed.

B11

Construction

Governor RFD (K)



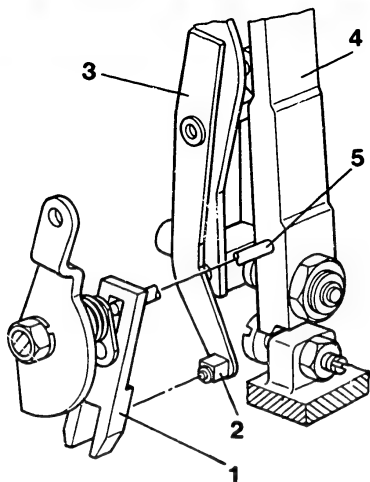

Fig. 21

- 1 = Supporting lever
- 2 = Block
- 3 = Floating lever
- 4 = Tension lever
- 5 = Pin

A pin is pressfitted into the side of the tension lever at its lower end. This pin fits in the groove in the top of the supporting lever. The block at the bottom of the floating lever fits into the groove in the bottom of the supporting lever.

The lever ratio can be greatly increased during high-speed control by the pin in the side of the tension lever, the supporting lever and the floating lever link mechanism.



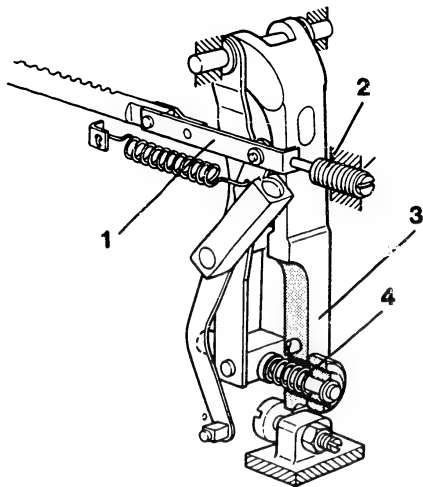

Fig. 22

- 1 = Rack connecting link
- 2 = Damper spring capsule
- 3 = Tension lever
- 4 = Idling spring

An idling spring which acts when the engine is idling is installed at the bottom of the tension lever.

A damper spring used to prevent the engine stopping during sudden deceleration is also mounted on the governor cover in such a way that it contacts the end of the rack connecting link.



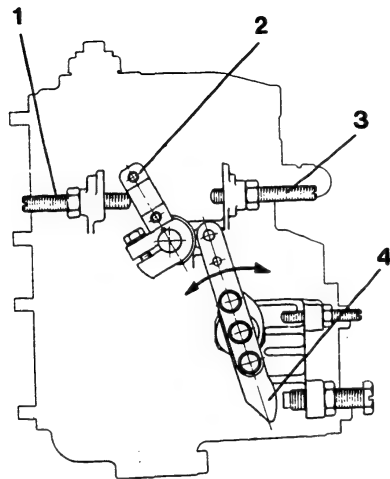

Fig. 23

- 1 = Maximum-speed stopper bolt
- 2 = Speed control lever
- 3 = Minimum-speed stopper bolt
- 4 = Load control lever

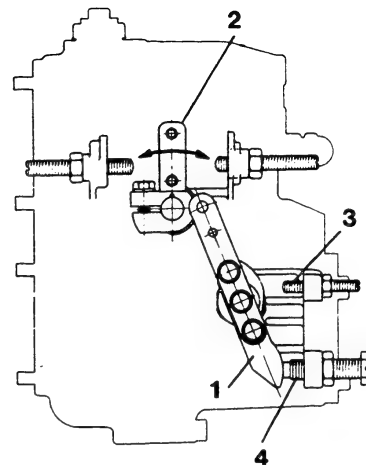

Fig. 24

- 1 = Load control lever
- 2 = Speed control lever
- 3 = Idle adjusting screw
- 4 = Full load stopper bolt

Due to this construction, use is possible either as a minimum-maximum speed governor, by fixing the speed control lever in the maximum speed position with the engine's link rod and operating the load control lever with the accelerator link rod (refer to Fig. 23); or as a variable-speed governor, by fixing the load control lever in the full load position and operating the speed control lever (refer to Fig. 24).

B14

Construction
Governor RFD (K)



B15

Construction
Governor RFD (K)



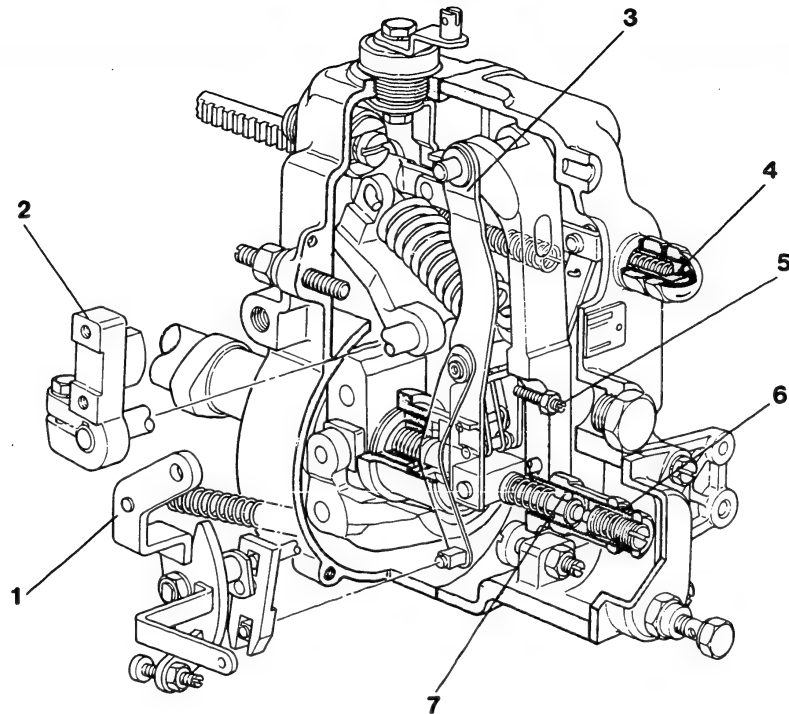

Fig. 25

RFD-K Type Governor

- 1 = Load control lever
- 2 = Speed control lever
- 3 = Guide lever
- 4 = Damper spring capsule

- 5 = Adjusting screw
- 6 = Torque control spring capsule
- 7 = Idling spring capsule

Figure 25 shows the construction of the RFD-K Type mechanical governor.

The construction of this governor is basically the same as that of the RFD Type governor except that an increase lever has been added to the guide lever so that it operates as a negative torque control governor.

B16

Construction
Governor RFD (K)



B17

Construction
Governor RFD (K)

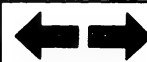

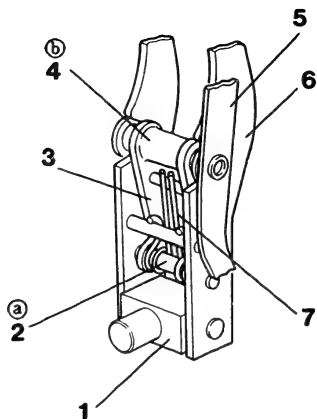

Fig. 26

- 1 = Shifter
- 2 = Pin (a)
- 3 = Increase lever
- 4 = Pin (b)
- 5 = Floating lever
- 6 = Guide lever
- 7 = Cancel spring

One end of the increase lever is connected to the guide lever by pin (a) and the other end is connected to the floating lever by pin (b). A cancel spring is provided between pins (a) and (b) so that the guide lever and increase lever move together.



The tension lever is also provided with an adjusting screw for adjusting the torque control stroke. The end of the adjusting screw contacts pin ⑥, which is press-fitted into the increase lever. It pushes the increase lever when the governor is operating as a negative torque control governor.

B19

Construction

Governor RFD (K)



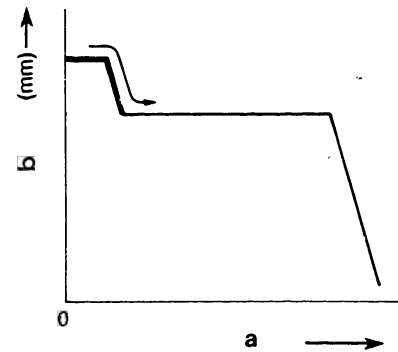
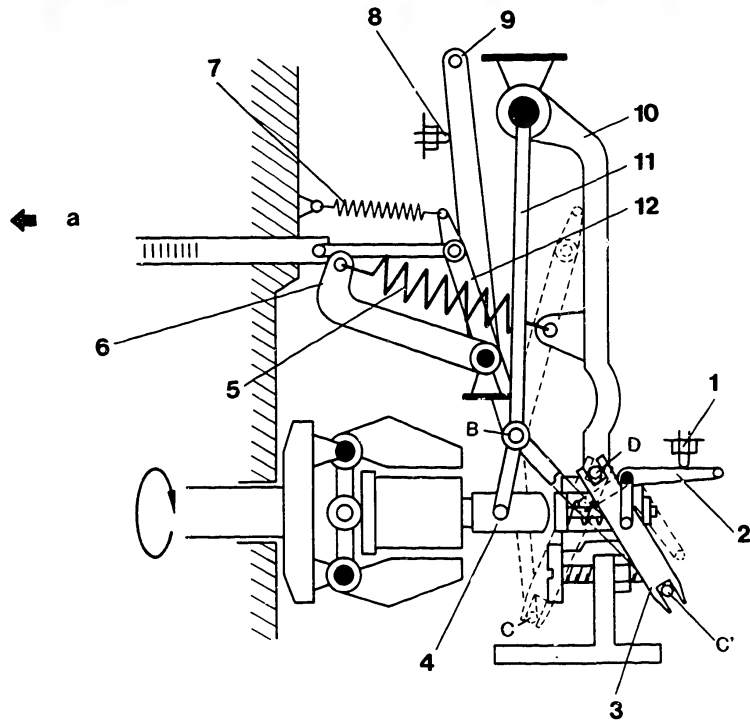

Fig. 27 RFD Type Governor

OPERATION

Engine Starting

● Minimum-Maximum Speed Governor Application

- 1 = Full load stopper bolt
- 2 = Load control lever
- 3 = Supporting lever
- 4 = Shifter
- 5 = Governor spring
- 6 = Speed setting lever
- a = Fuel-increase direction

- 7 = Start spring
- 8 = Maximum-speed stopper bolt
- 9 = Speed control lever (fixed)
- 10 = Tension lever
- 11 = Guide lever
- 12 = Floating lever

- a = Pump speed (rpm)
- b = Control rack position

B20	Operation	➔
	Governor RFD (K)	

B21	Operation	↔
	Governor RFD (K)	

When the engine is stopped, the flyweight is closed by the force of the governor spring, idling spring and start spring.

When the load control lever is then moved in the fuel-increase direction, the control rack is moved in the fuel-increase direction via the supporting lever and floating lever.

The start spring and idling spring then move the control rack past the full load position to obtain the maximum fuel injection quantity required to start the engine and therefore facilitate engine starting.

B22

Operation

Governor RFD (K)



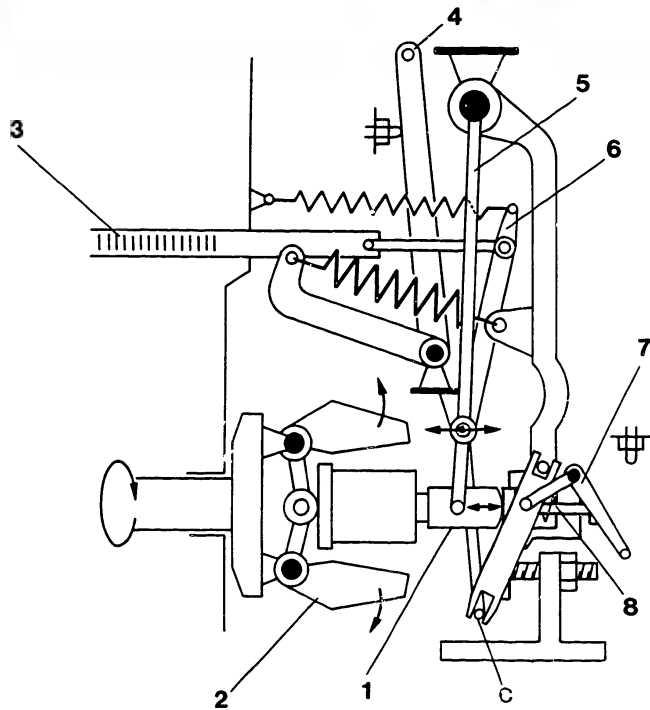
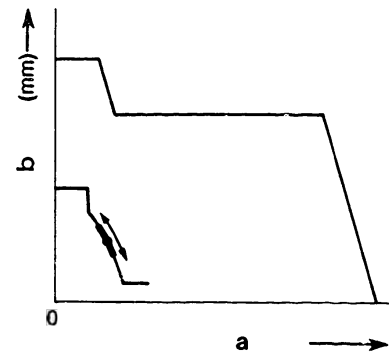

Fig. 28

Idling Control

- 1 = Shifter
- 2 = Flyweight
- 3 = Control rack
- 4 = Speed control lever
- 5 = Guide lever
- 6 = Floating lever
- 7 = Load control lever
- 8 = Idling spring



- a = Pump speed (rpm)
- b = Control rack position

B23

Operation
Governor RFD (K)



B24

Operation
Governor RFD (K)



After the engine starts and the load control lever returns to the idling position, the idling speed is stabilized at the position where the centrifugal force acting on the flyweight and the force of the start spring and idling spring balance.

When the engine speed varies due to a change in the load, this movement is transmitted to the control rack through the shifter and floating lever, changing the fuel injection quantity.

For example, if the engine speed decreases, the centrifugal force generated by the flyweight decreases and the shifter is moved to the left by the force of the idling spring (refer to Fig. 28).

When the shifter moves to the left, the control rack is moved in the fuel-increase direction through the guide lever and floating lever, and stops at the position where the centrifugal force and the force of the idling spring balance, thereby preventing the engine from stopping.

Conversely, if the engine speed starts to increase, the control rack is moved in the fuel-decrease direction, preventing any increase in the engine speed.



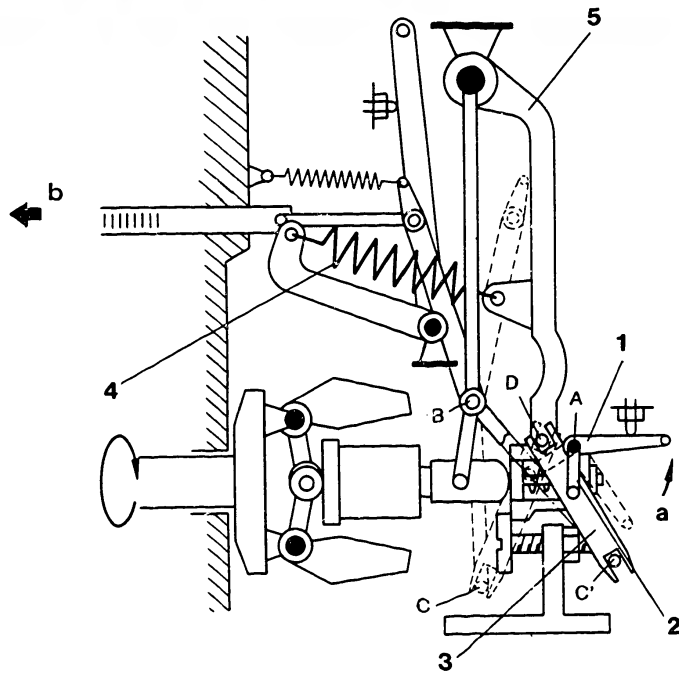
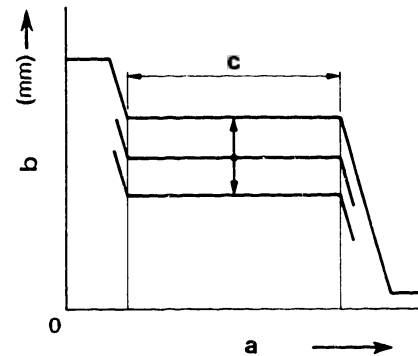

Fig. 29

Normal Service Operation

- 1 = Load control lever
- 2 = Eccentric shaft
- 3 = Supporting lever
- 4 = Governor spring
- 5 = Tension lever

a = Fuel-increase direction
 b = Control rack position



a = Pump speed (rpm)
 b = Control rack position
 c = Non-controlled zone

B26

Operation
 Governor RFD (K)



B27

Operation
 Governor RFD (K)

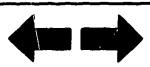

At intermediate speeds, the centrifugal force acting on the flyweight is relatively large and the idling spring is completely compressed. The shifter is in contact with the tension lever.

However, the centrifugal force of the flyweight is still not equal to the force of the governor spring.

Within the normal operating range, the operator moves the control rack by directly operating the load control lever, increasing and decreasing the fuel injection quantity.

For example, when the operator wishes to accelerate the vehicle and the load control lever is moved fully in the fuel-increase direction (to the position where it strikes the full load stopper bolt), the eccentric shaft rotates with point A as the fulcrum, and moves the supporting lever to C' from C (refer to Fig. 29).

With this movement the floating lever is rotated to the left with point B as the fulcrum to move the control rack in the fuel-increase direction.



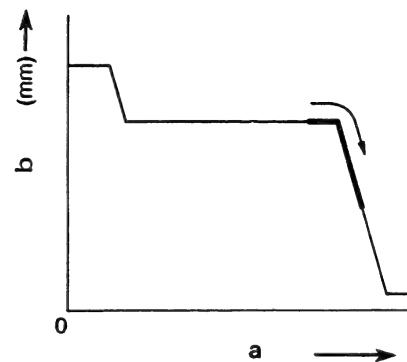
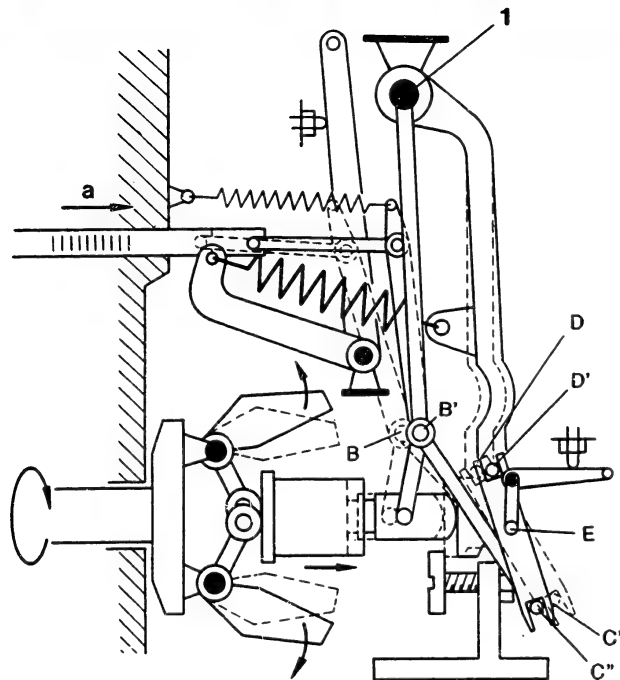

Fig. 30

Maximum-Speed Control

1 = Tension lever shaft
 a = Fuel-decrease direction

a = Pump speed (rpm)
 b = Control rack position

When the engine reaches maximum speed due to a load fluctuation, the centrifugal force of the flyweight overcomes the force of the governor spring and the flyweight starts to open outward.

As this motion moves the shifter and tension lever to the right, the guide lever's common fulcrum at point B moves to point B', and pin D of the tension lever moves to point D' (refer to Fig. 30).

C1

Operation
 Governor RFD (K)



C2

Operation
 Governor RFD (K)



The supporting lever then rotates around the eccentric shaft, and fulcrum point C' at the bottom of the floating lever moves to point C".

Through this movement, the control rack is pulled back in the fuel-decrease direction, and thus, the engine is prevented from exceeding the maximum allowable speed.

C3

Operation

Governor RFD (K)



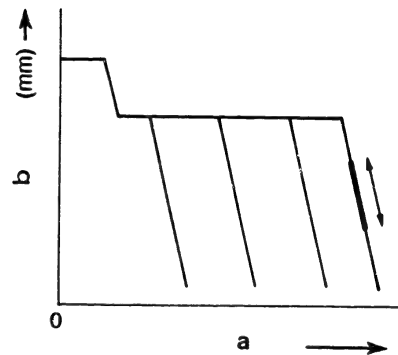
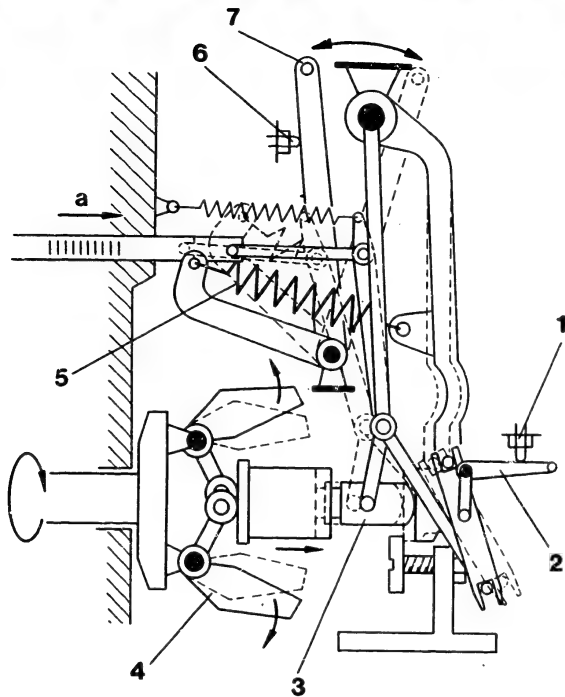

Fig. 31

● Variable Speed Governor Application

- 1 = Full load stopper bolt
- 2 = Load control lever
- 3 = Shifter
- 4 = Flyweight
- a = Fuel-decrease direction

- 5 = Governor spring
- 6 = Maximum speed stopper bolt
- 7 = Speed control lever

- a = Pump speed (rpm)
- b = Control rack position

In this case, as opposed to minimum-maximum speed governor operation, the load control lever is kept in contact with the full load stopper bolt and the speed control lever is moved.
The force of the governor spring can be set freely by moving the speed control lever.

G4

Operation
Governor RFD (K)



C5

Operation
Governor RFD (K)

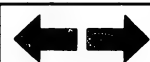

When the engine speed increases in response to a variation in engine load, as shown in Figure 31, the centrifugal force of the flyweight increases and the shifter stops at the engine speed where the force of the governor spring and the centrifugal force are balanced.

If the load on the engine then suddenly decreases, the centrifugal force of the flyweight becomes greater than the force of the governor spring, so that the shifter is moved to the right and the control rack is pulled in the fuel-decrease direction, preventing the engine speed from increasing.

Conversely, if the load increases, the engine speed drops, the force of the governor spring becomes greater than the centrifugal force of the flyweight and the control rack is moved in the fuel-increase direction.

For each new fluctuation in the engine load, the balance between the centrifugal force of the flyweight and the force of the governor spring changes and the shifter is moved to maintain a uniform engine speed.

C6

Operation
Governor RFD (K)



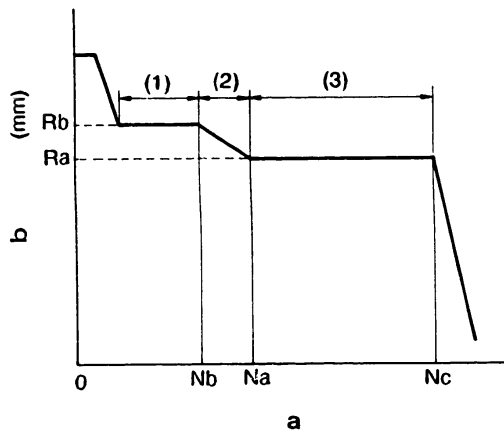

Fig. 32

a = Pump speed (rpm)
b = Control rack position

● Positive Torque Control Spring Operation

The torque control spring is mounted behind the idling spring at the bottom of the tension lever.

If the pump speed is Nb with the speed control lever held at the maximum speed stopper position and the load control lever held at the full load position, the centrifugal force generated by the flyweight becomes less than the set force of the torque control spring, and therefore the shifter cannot compress the torque control spring (refer to Fig. 32 (1), Fig. 33).

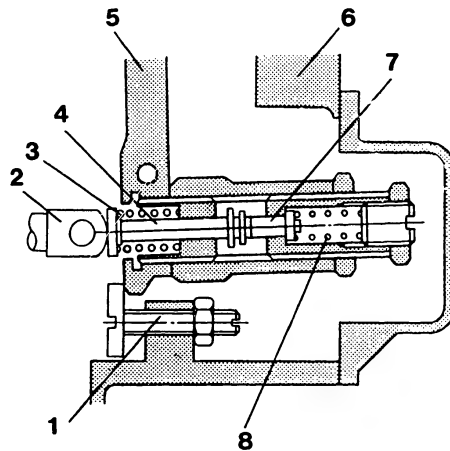

Fig. 33

- 1 = Stroke adjusting screw
- 2 = Shifter
- 3 = Idling spring
- 4 = No. 1 pushrod
- 5 = Tension lever
- 6 = Governor cover
- 7 = No. 2 pushrod
- 8 = Torque control spring

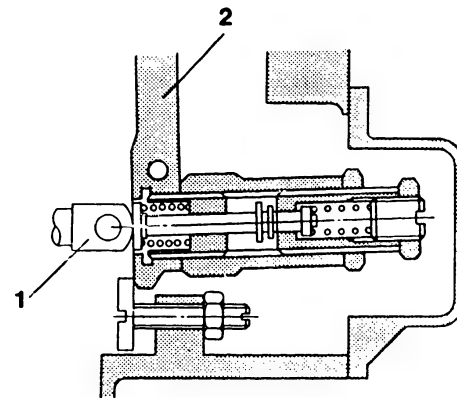

Fig. 34

- 1 = Shifter
- 2 = Tension lever



If the pump speed then increases further, the centrifugal force generated by the flyweight becomes greater than the set force of the torque control spring, and the torque control spring is compressed via the No. 1 pushrod.

The control rack is also moved in the fuel-decrease direction via the floating lever.

This motion continues until the shifter contacts the tension lever, and is called the torque control stroke (refer to Fig. 32 (2), Fig. 34).

After the shifter directly contacts the tension lever, the set force of the governor spring is greater than the centrifugal force generated by the flyweight; therefore, the tension lever cannot be moved (refer to Fig. 32 (3)).



RFD-K Type Governor

Although the operation of the RFD-K Type mechanical governor is basically the same as that of the RFD Type, operation is different at normal speeds because of the provision of an increase lever.

This operation is explained following.

C10

Operation

Governor RFD (K)



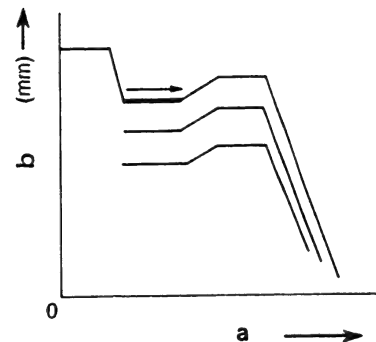
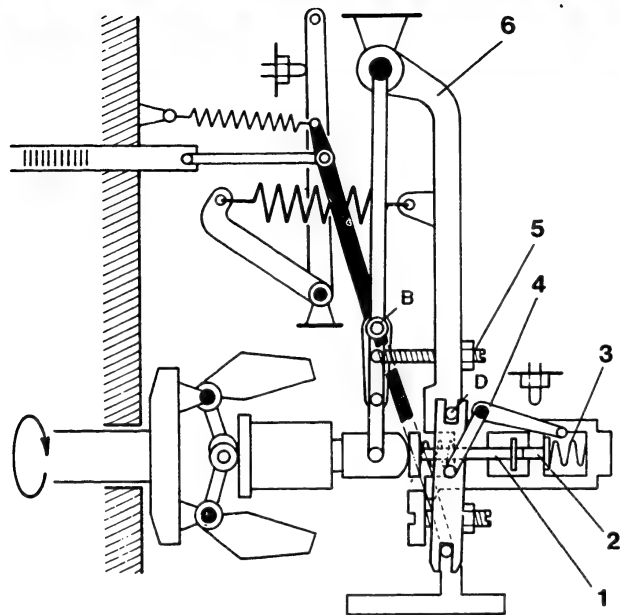

Fig. 35

Normal Speed Operation

- 1 = No. 1 pushrod
- 2 = No. 2 pushrod
- 3 = Torque control spring

- 4 = Load control lever
- 5 = Adjusting screw
- 6 = Tension lever

- a = Pump speed (rpm)
- b = Control rack position

When the load control lever is moved in the fuel-increase direction (i.e. the speed control lever is in the maximum speed position), the supporting lever is rotated by the eccentric shaft with point D as the fulcrum and the floating lever rotates around point B, moving the control rack in the fuel-increase direction to increase the engine speed (refer to Fig. 35).

As the engine speed increases, the No. 1 pushrod compresses the idling spring and contacts the No. 2 pushrod, at which position the centrifugal force of the flyweight overcomes the set force of the torque control spring.

At that time, the end of the adjusting screw which is mounted on the tension lever contacts the pin of the increase lever.

C11

Operation
Governor RFD (K)



C12

Operation
Governor RFD (K)



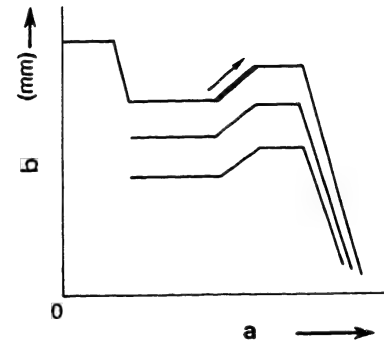
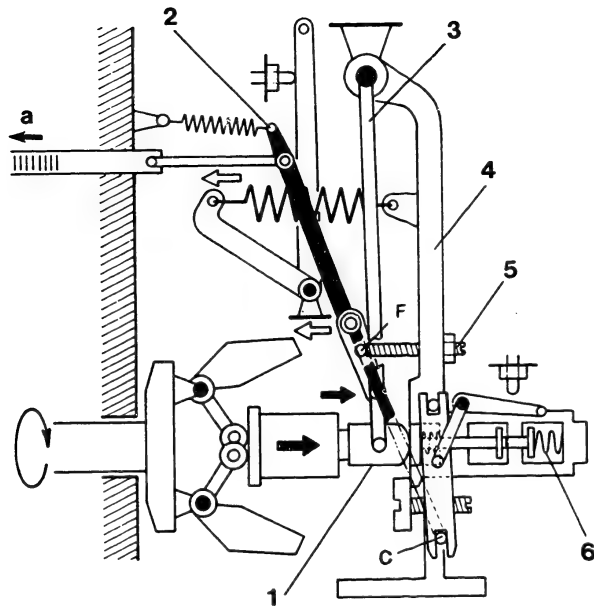

Fig. 36

Negative Torque Control Operation

- 1 = Shifter
- 2 = Floating lever
- 3 = Guide lever
- 4 = Tension lever
- 5 = Adjusting screw
- 6 = Torque control spring
- a = Fuel-increase direction

- a = Pump speed (rpm)
- b = Control rack position

If the engine speed increases even further, the centrifugal force generated by the flyweight becomes greater than the set force of the torque control spring and the shifter compresses the torque control spring while moving in the direction of the arrow → (refer to Fig. 36). The guide lever also moves to the right.

C13	Operation	↔
	Governor RFD (K)	

C14	Operation	↔
	Governor RFD (K)	

Due to the movement of the guide lever, the floating lever also tends to move to the right, pivoting around point C.

However, as the adjusting screw built into the tension lever is contacting the increase lever pin, the movement of the sleeve moves the floating lever to the left (in the fuel-increase direction with point F as the fulcrum) via the shifter, resulting in negative torque control.

This motion continues until the shifter contacts the tension lever.

C15

Operation

Governor RFD (K)



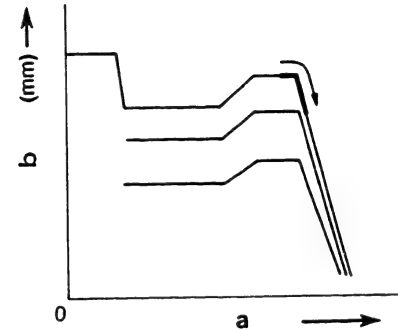
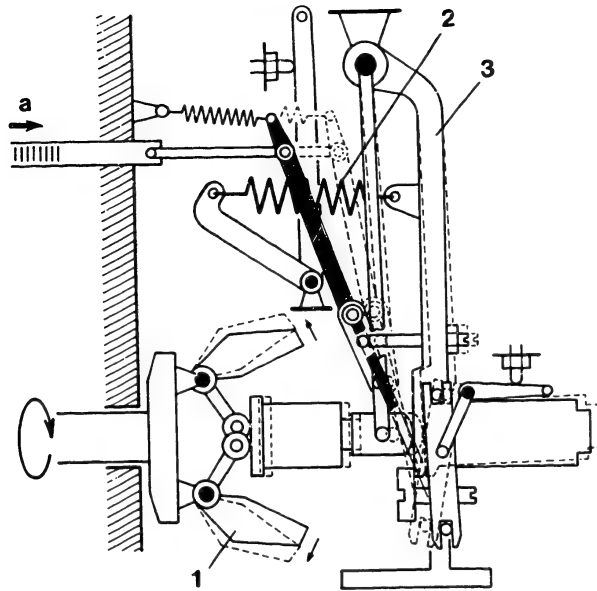

Fig. 37

Maximum Speed Control

- 1 = Flyweight
- 2 = Governor spring
- 3 = Tension lever

a = Fuel-decrease direction

- a = Pump speed (rpm)
- b = Control rack position

When the engine reaches the specified maximum speed due to a load fluctuation, the centrifugal force of the flyweight overcomes the force of the governor spring and the flyweight starts to open.

This motion moves the tension lever via the shifter, moving the control rack in the fuel-decrease direction and preventing the engine from exceeding the maximum allowable speed.

At this time, the increase lever's pin moves while remaining in contact with the tension lever's adjusting screw.

C16

Operation
Governor RFD (K)



C17

Operation
Governor RFD (K)



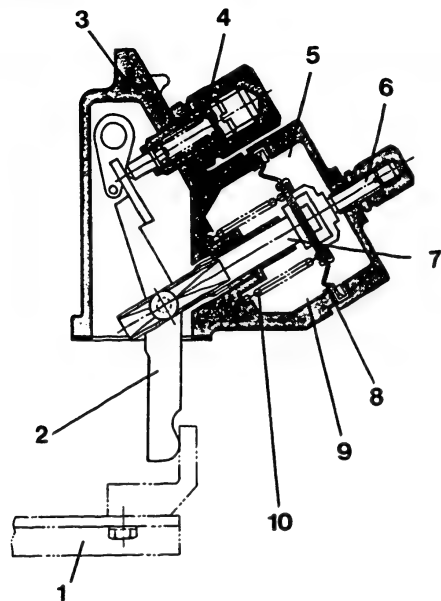

Fig. 38

- 1 = Control rack
- 2 = B.C.S. lever
- 3 = B.C.S. assembly
- 4 = Spring capsule for adjusting rack position
- 5 = Pressure chamber

- 6 = Screw A
- 7 = Pushrod
- 8 = Diaphragm
- 9 = Atmospheric chamber
- 10 = B.C.S. spring

ADDITIONAL DEVICES

Boost Compensator (B.C.S.)

The Governor Side (B.C.S.)

Construction

Figure 39 shows a cross section of the boost compensator mounted on the governor.

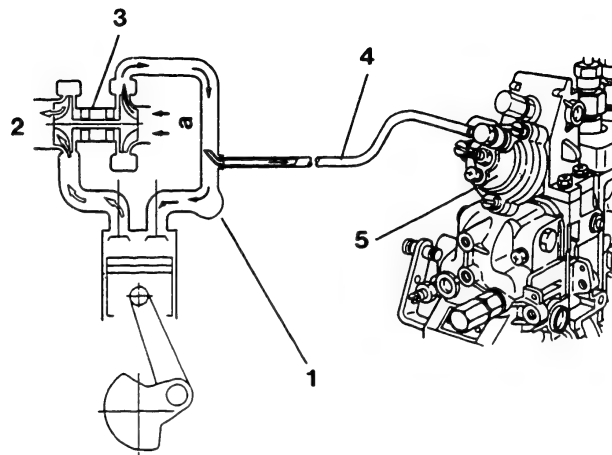

Fig. 39

- 1 = Inlet manifold
- 2 = Exhaust
- 3 = Turbocharger
- 4 = Pipe
- 5 = B.C.S.
- a = Suction

C18

Additional devices
Governor RFD (K)



C19

Additional devices
Governor RFD (K)



The interior of the boost compensator chamber is divided into an atmospheric chamber and a pressure chamber. A boost compensator spring with a pre-determined set force is built into the atmospheric chamber.

The pushrod moves together with the diaphragm, and a pin at one end connects it to the boost compensator lever. The other end is constantly held against screw A by the boost compensator spring. The bottom end of the boost compensator lever contacts the control rack and the top end contacts a spring capsule used for adjusting the control rack position.

The spring built into the spring capsule has a very strong set force and is designed so that it is only compressed when the engine is being started.

Operation

When the engine speed increases, the boost pressure generated by the turbocharger passes through a pipe to act on the pressure chamber of the boost compensator.



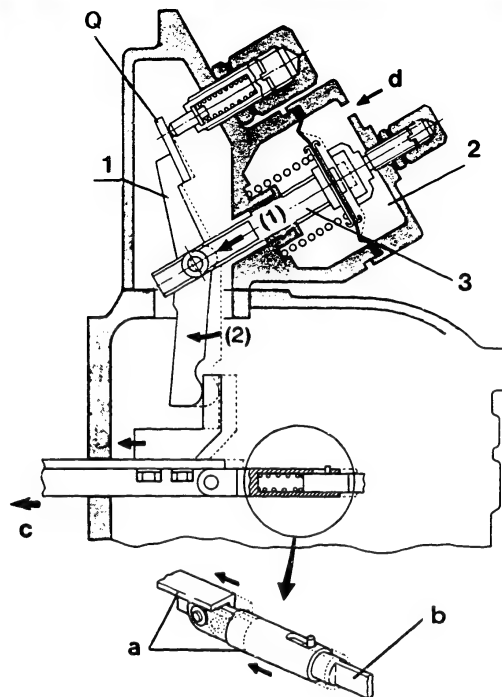

Fig. 40

- 1 = B.C.S. lever
- 2 = Pressure chamber
- 3 = Pushrod

- a = movable
- b = fixed
- c = Fuel-increase direction
- d = Boost pressure

When the boost pressure exceeds the set force of the boost compensator spring, the pushrod, which moves together with the diaphragm, is pushed in the direction of arrow (1).

The bottom of the boost compensator lever is therefore moved in the direction of arrow (2), with contact point Q between the spring capsule and boost compensator lever as the fulcrum.

C21

Additional devices
Governor RFD (K)

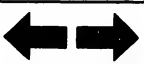

C22

Additional devices
Governor RFD (K)

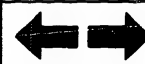

As the load control lever of the governor itself is in the full load position and the floating lever is fixed, the control rack is moved in the fuel-increase direction by the force of the cancel spring and a quantity of fuel adequate for the amount of intake air pressurized by the turbocharger is injected into the combustion chamber.

C23

Additional devices

Governor RFD (K)



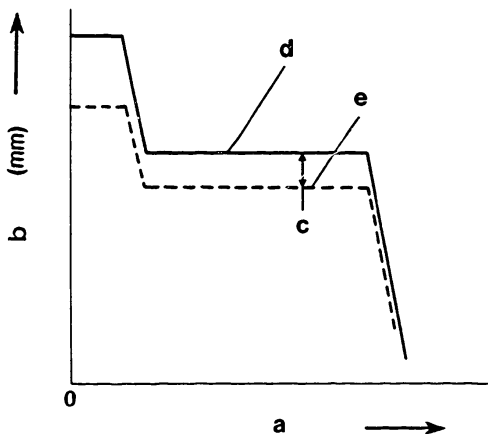

Fig. 41

- a = Pump speed (rpm)
- b = Control rack position
- c = Boost compensator stroke
- d = B.C.S. operating
- e = B.C.S. not operating

The governing characteristics of the boost compensator-equipped fuel injection pump are shown in Figure 41.

At specified maximum boost compensator pressure the fuel injection quantity is increased an amount corresponding to control rack position $R_b - R_a$ (i.e boost compensator stroke.)

This increase is in addition to the full-load fuel injection quantity.



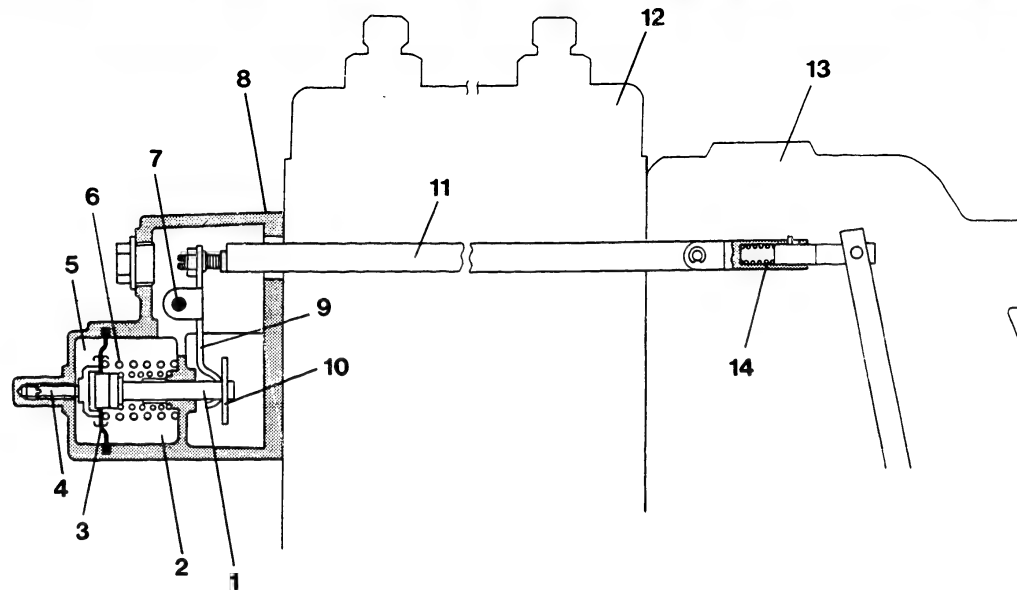

Fig. 42

The Drive Side (B.C.S.)

- 1 = Pushrod
- 2 = Atmospheric chamber
- 3 = Diaphragm
- 4 = Screw A
- 5 = Pressure chamber
- 6 = B.C.S. spring
- 7 = Pin

- 8 = B.C.S. assembly
- 9 = B.C.S. lever
- 10 = Disc
- 11 = Control rack
- 12 = Pump
- 13 = Governor
- 14 = Cancel spring

Construction

Figure 42 shows a cross section of the boost compensator mounted on the drive side. The interior of the boost compensator chamber is divided into an atmospheric chamber and a pressure chamber.

G25

Additional devices
Governor RFD (K)

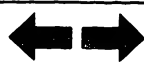

G26

Additional devices
Governor RFD (K)



A boost compensator spring with a pre-determined set force is built into the atmospheric chamber.

The pushrod moves together with the diaphragm and a disk at one end contacts the boost compensator lever.

The other end is constantly held against screw A by the boost compensator spring.

A pin in the center of the B.C.S. body holds the boost compensator lever, while the bottom end of the boost compensator lever contacts the control rack.



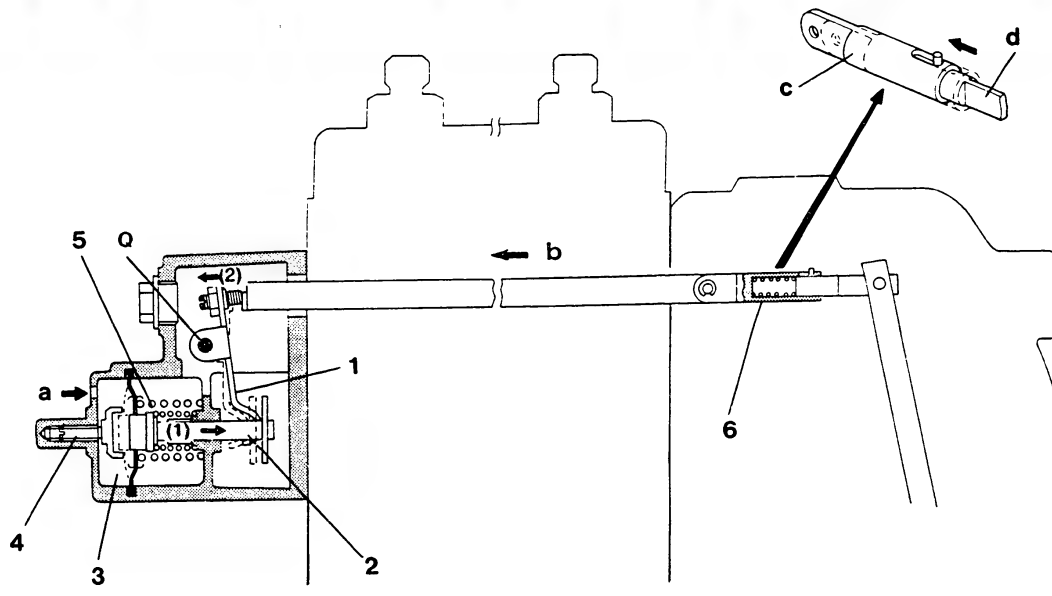

Fig. 43

- 1 = B.C.S. lever
- 2 = Pushrod
- 3 = Pressure chamber
- 4 = Screw A
- 5 = B.C.S. spring
- 6 = Cancel spring

- a = Boost pressure
- b = Fuel-increase direction
- c = movable
- d = fixed

Operation

When the engine speed increases, the boost pressure generated by the turbocharger passes through a pipe to act on the pressure chamber of the boost compensator.

When the boost pressure exceeds the set force of the boost compensator spring, the pushrod, which moves with the diaphragm, is pushed in the direction of arrow (1).

D1

Additional devices
Governor RFD (K)

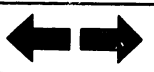

D2

Additional devices
Governor RFD (K)

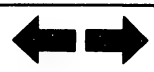

The bottom of the boost compensator lever is moved in the direction of arrow (2) with point Q as the fulcrum.

The control rack is therefore moved in the fuel-increase direction by the force of the cancel spring, and a quantity of fuel adequate for the amount of intake air pressurized by the turbocharger is injected into the combustion chamber.

D3

Additional devices

Governor RFD (K)



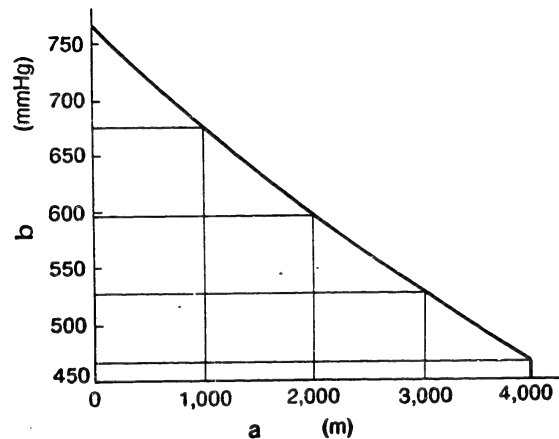

Fig. 44 Relationship between atmospheric pressure and altitude

a = Altitude
b = Atmospheric pressure

Aneroid Compensator (A.C.S.)

Purpose

Figure 44 shows the relationship between atmospheric pressure and altitude. Atmospheric pressure decreases as altitude increases.

Figure 45 shows the relationship between atmospheric pressure and air density. Air density decreases as the atmospheric pressure decreases.

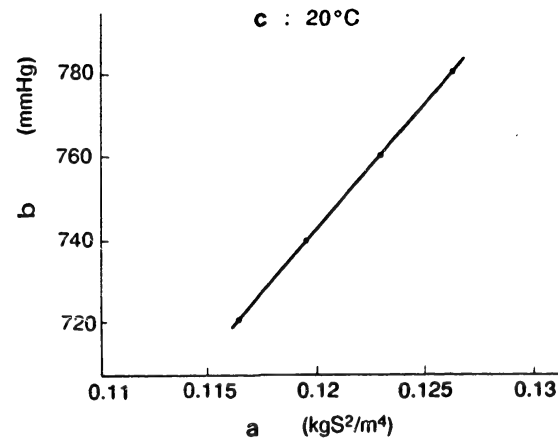
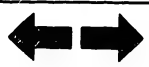

Fig. 45 Dry air density

a = Density
b = Atmospheric pressure
c = Air temperature

D4

Additional devices
Governor RFD (K)



D5

Additional devices
Governor RFD (K)

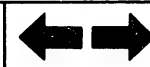

A vehicle with a diesel engine adjusted to function at low altitudes may experience the following problems due to excessive fuel injection when used at high altitudes.

1. Increased emission of black smoke.
2. Insufficient engine output, despite increased fuel consumption.
3. Carbon deposits in the combustion chamber (thus shortening the service life of the engine.)

D6

Additional devices

Governor RFD (K)



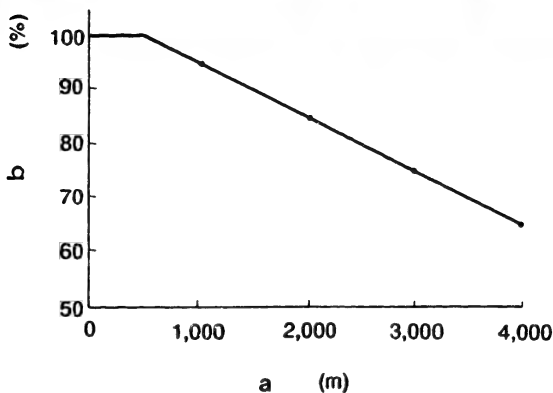

Fig. 46

a = Altitude

b = Full-load injection quantity

In order to prevent the above problems, the full-load fuel injection quantity must be adjusted to compensate for altitude, as shown in Figure 46.



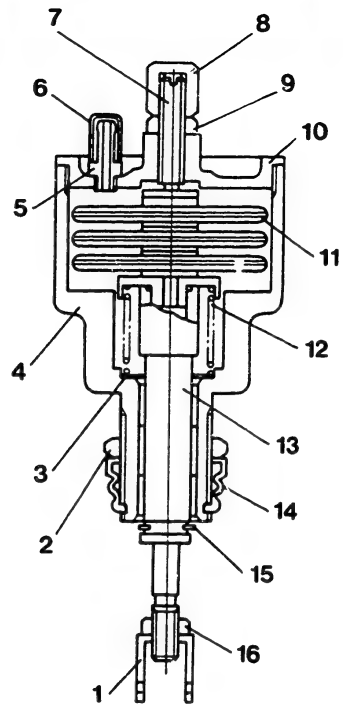
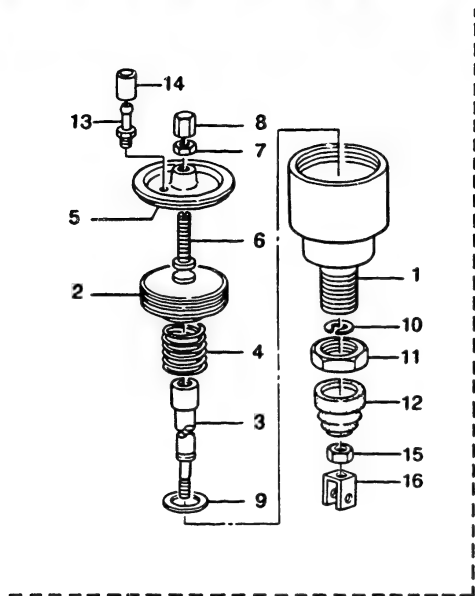

Fig. 47

Construction and Operation

- 1 = Clevis (16)
- 2 = Locknut (11)
- 3 = Washer (9)
- 4 = Housing (1)
- 5 = Joint (13)

- 6 = Air inlet cap (14)
- 7 = Adjusting bolt (6)
- 8 = Cap nut (8)
- 9 = Nut (7)
- 10 = Cover (5)

- 11 = Bellows (2)
- 12 = A.C.S. spring (4)
- 13 = Pushrod (3)
- 14 = Rubber boot (12)
- 15 = Snapping (10)
- 16 = Nut (15)

The A.C.S. is attached to the outside of the governor by a bracket.

The clevis at the end of the pushrod is connected to the A.C.S. lever (1) of the governor (Fig. 48).

As shown in Figure 47, the A.C.S. includes a bellows under which the spring and pushrod are assembled.

A joint and cap, with an air inlet, are installed in the bellows.

The bellows, which extends and retracts according to the atmospheric pressure, moves the pushrod against the pre-adjusted spring.

The adjusting bolt attached to the top of the bellows is used to adjust the spring force and the initial pushrod position.

D10

Additional devices

Governor RFD (K)



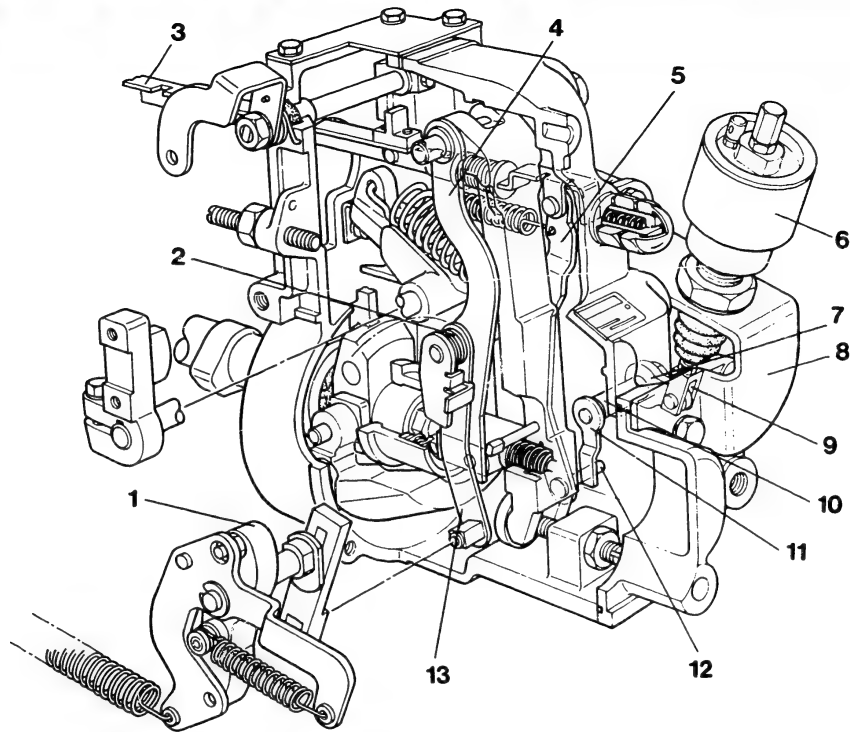

Fig. 48

- 1 = Load control lever
- 2 = Return spring
- 3 = Control rod
- 4 = Guide lever
- 5 = Floating lever (1/2)
- 6 = A.C.S. assembly

- 7 = A.C.S. lever (1)
- 8 = Bracket
- 9 = Clevis
- 10 = Shaft
- 11 = A.C.S. lever (2)
- 12 = Pin of floating lever
- 13 = Floating lever (2/2)

Figure 48 shows the construction of the RFD type governor with the A.C.S.

D11

Additional devices
Governor RFD (K)



D12

Additional devices
Governor RFD (K)



Figure 48 shows the construction of the RFD type governor with the A.C.S.

The clevis at the end of the A.C.S. is connected directly to A.C.S. lever (1) of the governor, allowing the shaft to move together with A.C.S. lever (2).

When the A.C.S. functions, A.C.S. lever (2) contacts the pin of the floating lever (1/2).

D13

Additional devices

Governor RFD (K)



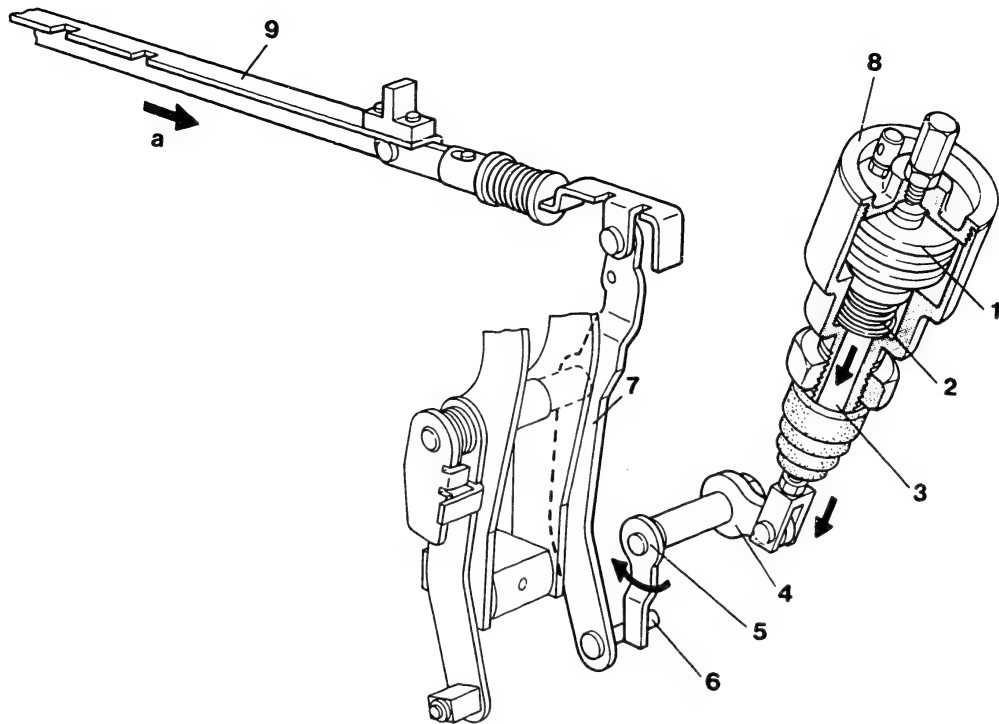

Fig. 49

- 1 = Bellows
- 2 = A.C.S. spring
- 3 = Pushrod
- 4 = A.C.S. lever (1)
- 5 = A.C.S. lever (2)
- a = Fuel-decrease direction

- 6 = Pin of floating lever (1/2)
- 7 = Floating lever (1/2)
- 8 = A.C.S. assembly
- 9 = Control rack

D14

Additional devices
Governor RFD (K)



D15

Additional devices
Governor RFD (K)

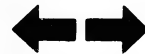

As the altitude increases, the atmospheric pressure decreases and the bellows extends accordingly.

When the bellows' extension force exceeds the A.C.S. spring force, the bellows moves the pushrod downward, activating A.C.S. lever (1).

A.C.S. lever (1) then moves the lever shaft, and A.C.S. lever (2) contacts the pin of the floating lever (1/2), pulling the control rack toward the governor side and decreasing the fuel injection quantity, irrespective of the load control lever's position.

D16

Additional devices

Governor RFD (K)



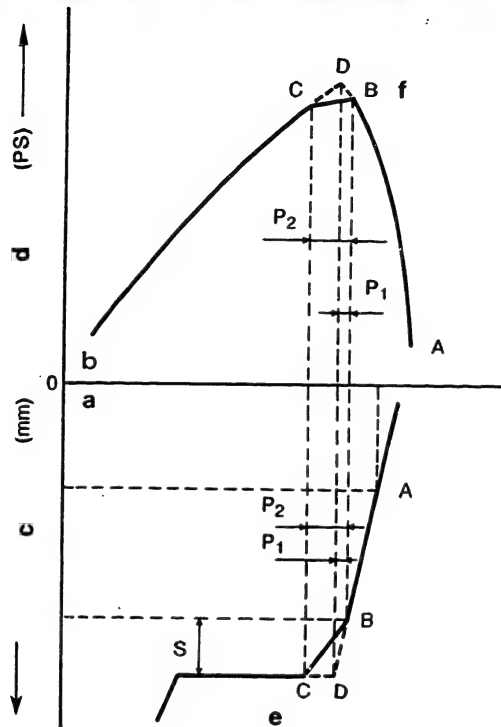

Fig. 50

Torque Spring

- a = Pump speed (rpm)
- b = Engine speed (rpm)
- c = Control rack position
- d = Out-put
- e = (Full load)
- f = (Rated output)

Purpose

Figure 50 shows engine and governor performance graphs for the full load position.

D17

Additional devices
Governor RFD (K)



D18

Additional devices
Governor RFD (K)

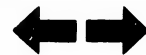

When operating at the rated output (point B) and the engine speed decreases because of a sudden increase in the load, the control rack will move from B to D if there is no torque spring. The change in speed during this time will be P_1 . If a torque spring is used, however, the control rack will move from B to C and the change in speed will be P_2 .

Even though the change in speed is either P_1 or P_2 , depending on whether or not a torque spring is used, the movement of the control rack is "S" in both cases and only the engine speed changes.

That is, because of the effect of the torque spring, time is required for the engine speed to decrease and as the fuel injection quantity increases during this time, the engine torque also increases. Also, the operator can tell that the engine speed has decreased because of an increase in the load, leaving time to change gears or take other necessary actions. Because of this, with the proper torque spring, it is possible to prevent the engine from stalling due to sudden load increases, and higher engine output can be obtained.

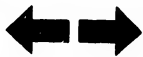

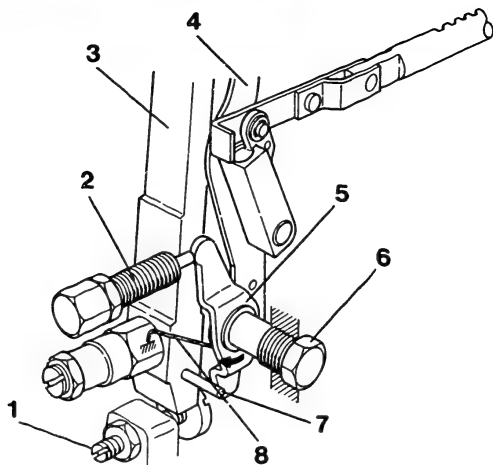

Fig. 51

- 1 = Stroke adjusting screw
- 2 = Torque spring capsule
- 3 = Tension lever
- 4 = Floating lever
- 5 = Torque lever
- 6 = Plug
- 7 = Pin
- 8 = Return spring

Construction

The construction of the torque spring used in the RFD Type mechanical governor is shown in Figure 36.

The torque lever is held against the plug built into the bottom of the governor cover by a snapping.



The force of the return spring keeps the bottom end of the torque lever in constant contact with the pin pressfitted to the tension lever. The top end contacts the torque spring capsule's pushrod.

A spring with a pre-determined set force is built into the torque spring capsule. This spring, through the pushrod, acts to maintain a clearance between the bottom of the tension lever and the stroke adjusting screw.

During normal operation, however, when the force of the governor spring is stronger than the force of the torque spring, the bottom end of the tension lever contacts the stroke adjusting screw.



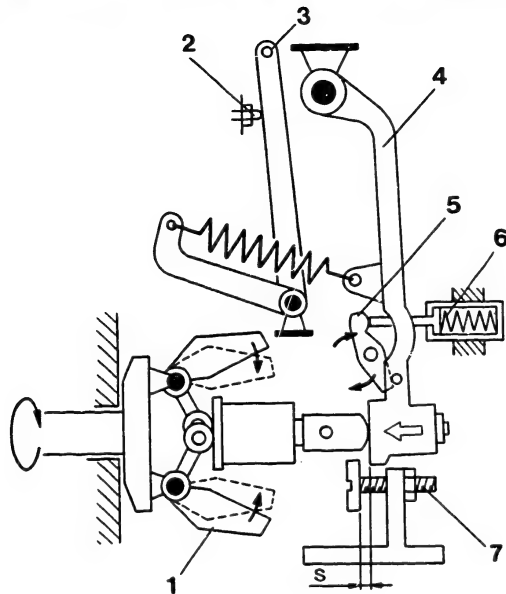
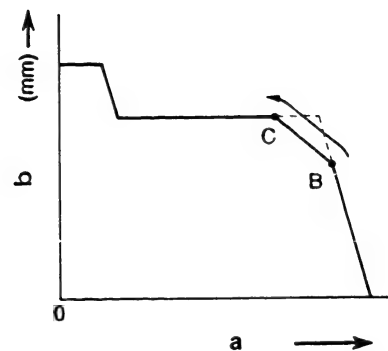

Fig. 52

- 1 = Flyweight
- 2 = Maximum speed stopper bolt
- 3 = Speed control lever
- 4 = Tension lever
- 5 = Torque lever
- 6 = Torque spring
- 7 = Stroke adjusting screw



- a = Pump speed (rpm)
- b = Control rack position

Operation

When operating at the rated output (point B) with the load control lever at the full load position and the speed control lever at the maximum speed position, the centrifugal force of the flyweight is greater than the force of the governor spring; therefore, the distance between the bottom of the tension lever and the stroke adjusting screw is "S".

D22

Additional devices
Governor RFD (K)

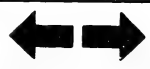

D23

Additional devices
Governor RFD (K)



When operating at the rated output (point B) with the load control lever at the full load position and the speed control lever at the maximum speed position, the centrifugal force of the flyweight is greater than the force of the governor spring; therefore, the distance between the bottom of the tension lever and the stroke adjusting screw is "S".

If the engine load is then increased, the engine speed will drop, the centrifugal force of the flyweight will decrease and the tension lever will be pushed in the fuel-increase direction.

However, as the tension lever cannot move suddenly because of the opposing force of the torque spring, the control rack moves slowly from point B to point C, and the engine is prevented from stalling, as was explained above.



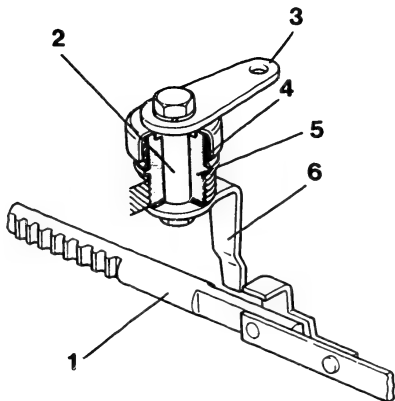

Fig. 53

- 1 = Control rack
- 2 = Stop lever shaft
- 3 = Stopping lever
- 4 = Return spring
- 5 = Bush
- 6 = Stop lever

Stopping Device

There are two methods of stopping the engine: cutting off the air supplied to the cylinders and cutting off the fuel oil supplied to the combustion chambers. In this manual, the operation of a stopping device which utilizes the latter method will be explained.



Construction

The stopping device is mounted in the top of the governor housing.

The stop lever shaft is supported by a bush and the stopping lever is attached to the top of this shaft by a bolt, as seen in Figure 53.

D 26

Additional devices

Governor RFD (K)



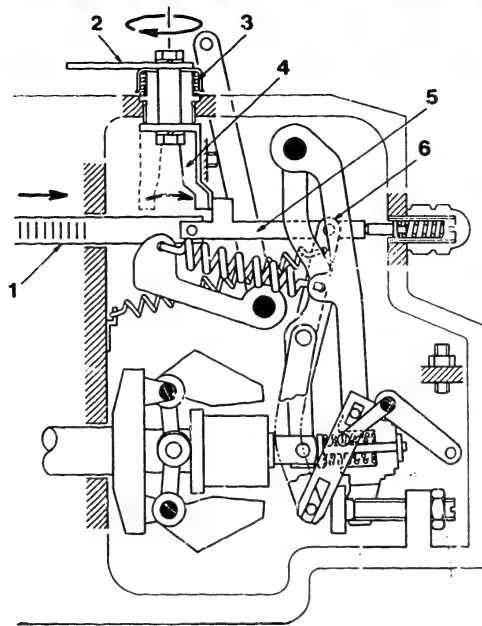

Fig. 54

Operation

- 1 = Control rack
- 2 = Stopping lever
- 3 = Return spring

- 4 = Stop lever
- 5 = Link
- 6 = Floating lever

• When not operating

When the stopping lever is not being operated, the force of the return spring keeps the stop lever in a position where it does not affect control rack operation (dotted line in Fig. 54).

• When operating

When the stopping lever is moved to the stop side, the stop lever, via the stop lever shaft, moves the control rack in the fuel-decrease direction to return the control rack to the non-injection zone, whatever the speed. When the stopping lever is released, it is returned to the non-operating position by the return spring.

D27

Additional devices
Governor RFD (K)



D28

Additional devices
Governor RFD (K)

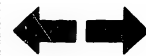

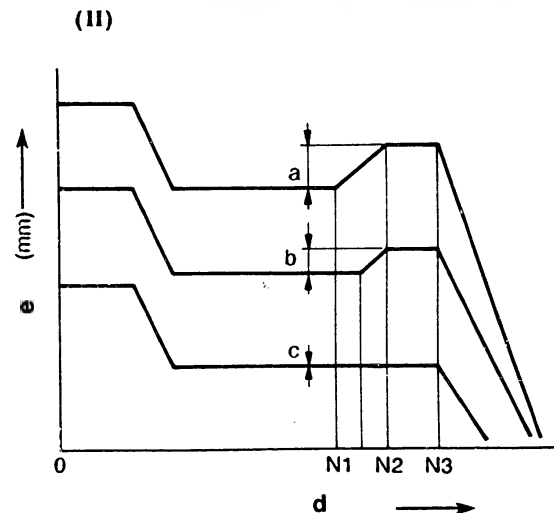
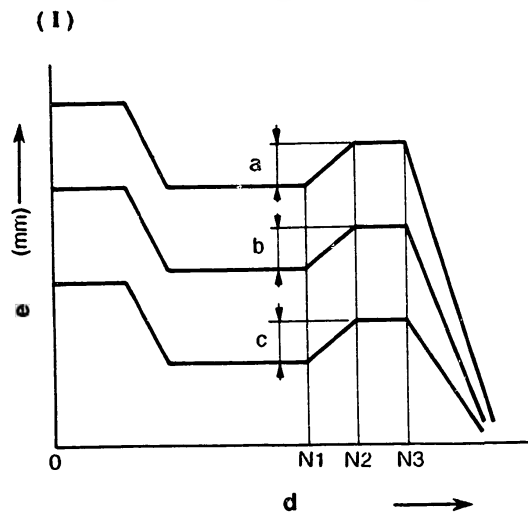

Fig. 55

Reduction Device (installed on RFD-K governor)

(I) = RFD-K Type performance graph

(II) = Reduction device equipped RFD-K Type performance graph

d = Pump speed (rpm)
e = Control rack position

d = Pump speed (rpm)
e = Control rack position

- Torque control stroke: $a = b = c$
- Speed at which the torque control spring starts to take effect : constant
- Speed at which the torque control spring stops having effect : constant

- Torque control stroke: $a > b > c (= 0)$
- Speed at which the torque control spring starts to take effect : variable
- Speed at which the torque control spring stops having effect : constant

E1

Additional devices
Governor RFD (K)



E2

Additional devices
Governor RFD (K)



Reduction Device (cont' d)

With the RFD-K Type mechanical governor, the negative torque control stroke normally remains constant throughout the entire speed range, regardless of the position of the load control lever, as shown in Figure 55-(I).

With RFD-K Type mechanical governors equipped with a reduction device, the negative torque control stroke varies depending on the position of the load control lever.

Negative torque control is not effective when the load control lever is in the idling position.

The speed at which the torque control spring starts taking effect also varies with the position of the load control lever.

Thus, when the load control lever is returned from the full load position to the idling position, the negative torque control stroke is reduced, becoming zero at the idling position.

E3

Additional devices

Governor RFD (K)



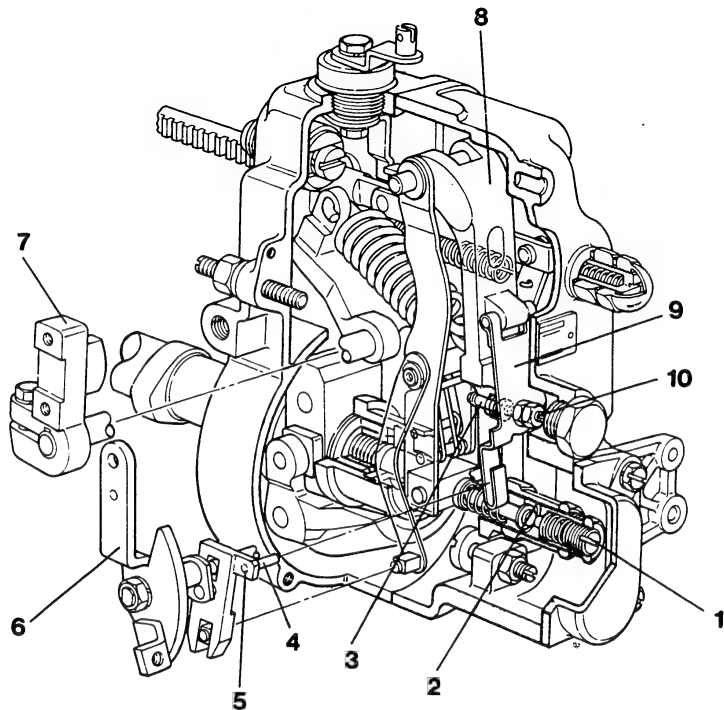
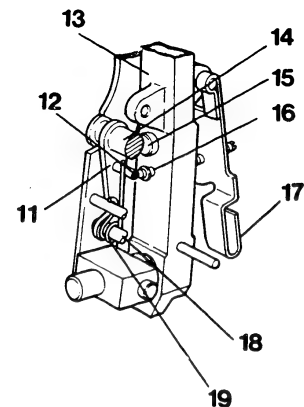

Fig. 56

- 1 = Torque control spring capsule
- 2 = Idling spring capsule
- 3 = Pushrod
- 4 = Pin
- 5 = Supporting lever

- 6 = Load control lever
- 7 = Speed control lever
- 8 = Tension lever
- 9 = Sub-lever
- 10 = Screw



- 11 = Increase lever
- 12 = Pin A
- 13 = Tension lever
- 14 = Pin C
- 15 = Pin D
- 16 = Pushrod
- 17 = Sub-lever
- 18 = Pin B
- 19 = Cancel spring

Construction

E4

Additional devices
Governor RFD (K)

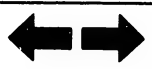

E5

Additional devices
Governor RFD (K)

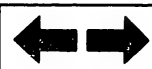

Construction (cont' d)

As shown in Figure 56, the construction of the reduction-device-equipped RFD-K Type mechanical governor is basically the same as that of the normal RFD-K Type.

A pin has been added to the top of the supporting lever to reduce negative torque control, and a sub-lever has been added to the back of the tension lever.

The supporting lever pin engages a fork at the bottom of this sub-lever.

A pushrod is built into the middle of the tension lever, one end of which contacts the torque control stroke adjustment screw located on the sub-lever. Another pin, D, is located above the pushrod to prevent positive torque control.

As with the RFD-K Type mechanical governor without a reduction device, increase lever is used to provide negative torque control operation.

One end of the increase lever is connected to the guide lever by pin B. The other end is connected to the floating lever by pin C. A cancel spring is mounted on pins A and B to act on the increase lever during negative torque control.

The pushrod mounted on the tension lever contacts pin A of the increase lever, and pin D (used to prevent the positive torque control) contacts pin C.

The idling spring and torque control spring are both attached to the bottom of the tension lever, as with the RFD-K Type mechanical governor without a reduction device.



- **Operation**

Operation outside the torque control range is the same as that of the normal RFD-K governor and is omitted here.

In the following explanation, it will be assumed that the speed control lever is in the maximum speed position.

E7

Additional devices

Governor RFD (K)



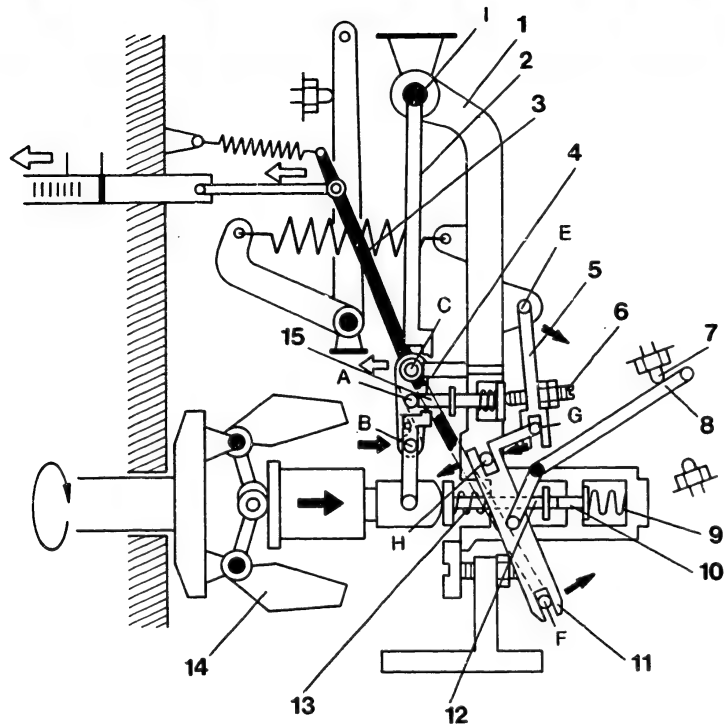
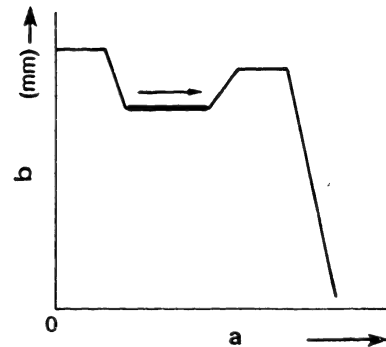

Fig. 57

- 1 = Tension lever
- 2 = Guide lever
- 3 = Floating lever
- 4 = Pin D
- 5 = Sub-lever
- 6 = Screw
- 7 = Full load stopper bolt
- 8 = Load control lever

- 9 = Torque control spring
- 10 = No. 2 pushrod
- 11 = Supporting lever
- 12 = No. 1 pushrod
- 13 = Idling spring
- 14 = Flyweight
- 15 = Pushrod



- a = Pump speed (rpm)
- b = Control rack position

E8

Additional devices
Governor RFD (K)



E9

Additional devices
Governor RFD (K)

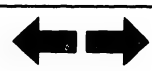

Full Load Position Operation

When the load control lever is moved to the full load side (pivoting around the control lever shaft), the supporting lever is pivoted counterclockwise around fulcrum H. This causes the sub-lever (and point G) to pivot clockwise around fulcrum E.

The screw then moves leftward together with the sub-lever, pushing the pushrod to the left.

The movements of the guide lever and floating lever are the same as those of the normal RFD-K and are omitted here.

When the pump speed increases in this status, the centrifugal force of the flyweight overcomes the force of the idling spring, thus compressing it, and the No. 1 pushrod contacts the No. 2 pushrod.

The pushrod mounted on the tension lever contacts pin A, and pin D contacts pin C on the increase lever.



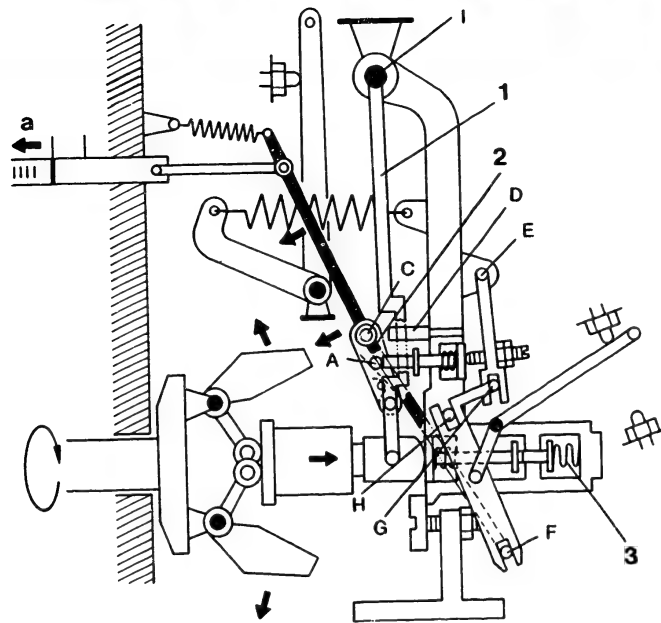
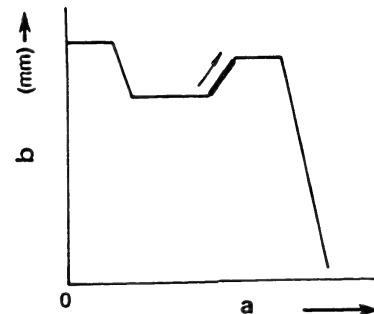

Figure 58

- 1 = Guide lever
- 2 = Increase lever
- 3 = Torque control spring
- a = Fuel increase direction



- a = Pump speed (rpm)
- b = Control rack position

As the pump speed continues to increase, the centrifugal force of the flyweight overcomes the force of the torque control spring and the increase lever's cancel spring, causing the guide lever to rotate counterclockwise with I as the fulcrum.

Since fulcrum B of the increase lever is connected to the guide lever, however, fulcrum B is moved to the right by the movement of the guide lever to the right.

Thus, the increase lever rotates counterclockwise with A as the fulcrum, which then moves fulcrum C to the left.

E11

Additional devices
Governor RFD (K)

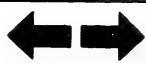

E12

Additional devices
Governor RFD (K)

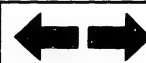

Since fulcrum C of the increase lever is connected to the floating lever, however, the floating lever is rotated counterclockwise with F as the fulcrum by the leftward movement of fulcrum C. This in turn moves the control rack in the fuel-increase direction.

E13

Additional devices

Governor RFD (K)



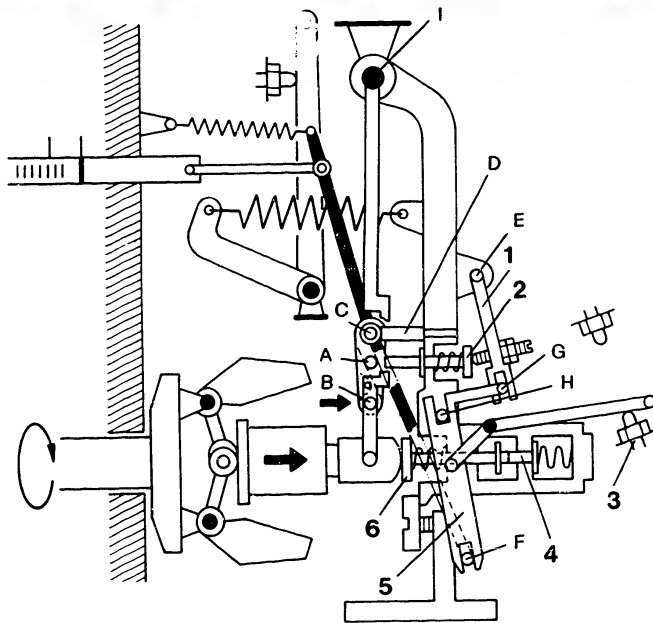
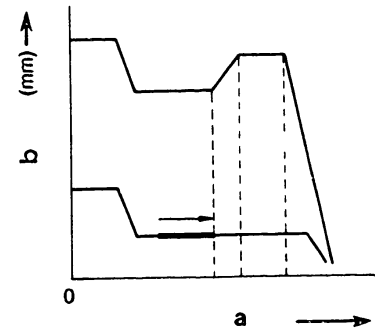

Fig. 59

- 1 = Sub-lever
- 2 = Pushrod
- 3 = Idle adjusting screw

- 4 = No. 2 Pushrod
- 5 = Supporting lever
- 6 = No. 1 Pushrod



- a = Pump speed (rpm)
- b = Control rack position

Idling Position Operation

When the load control lever is returned to the idling position, the supporting lever rotates clockwise with H as the fulcrum, and point G on the back of the tension lever rotates counterclockwise with E as the fulcrum. Consequently, the screw located on the sub-lever also moves to the right and the pushrod is moved to the right by the force of the spring.

When the pump speed increases, the centrifugal force of the flyweight compresses the idling spring via the shifter. When pushrods No. 1 and No. 2 contact, the increase lever pin contacts the tension lever's pin D. Pivot pin A, however, does not contact the pushrod.

E14

Additional devices
Governor RFD (K)

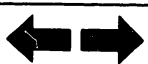

E15

Additional devices
Governor RFD (K)

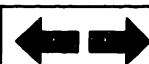

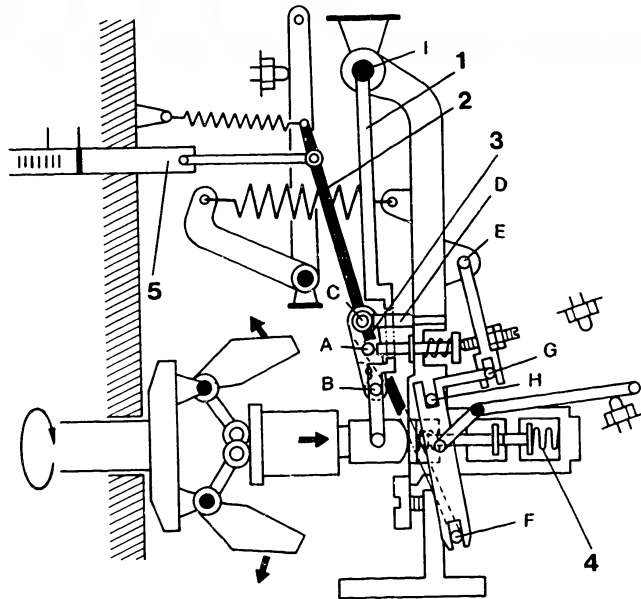
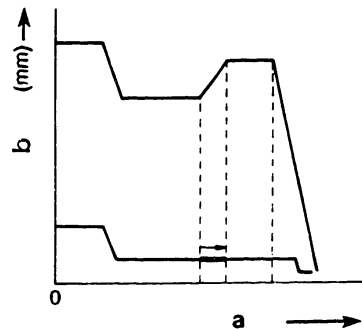

Fig. 60

- 1 = Guide lever
- 2 = Floating lever
- 3 = Increase lever

- 4 = Torque control spring
- 5 = Control rack



- a = Pump speed (rpm)
- b = Control rack position

When the pump speed increases even further and the centrifugal force of the flyweight overcomes the force of the torque control spring and the increase lever's cancel spring, the guide lever rotates counterclockwise with I as the fulcrum and the increase lever moves to the right.

Point C, however, cannot move because it is in contact with pin D located on the tension lever.

Point B, on the other hand, moves to the right together with the guide lever because it is attached to the guide lever.

Therefore, the increase lever rotates counterclockwise around fulcrum C. The floating lever does not move because point C does not move, and therefore the control rack does not move.

E16

Additional devices
Governor RFD (K)

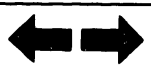

E17

Additional devices
Governor RFD (K)

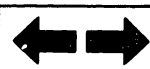

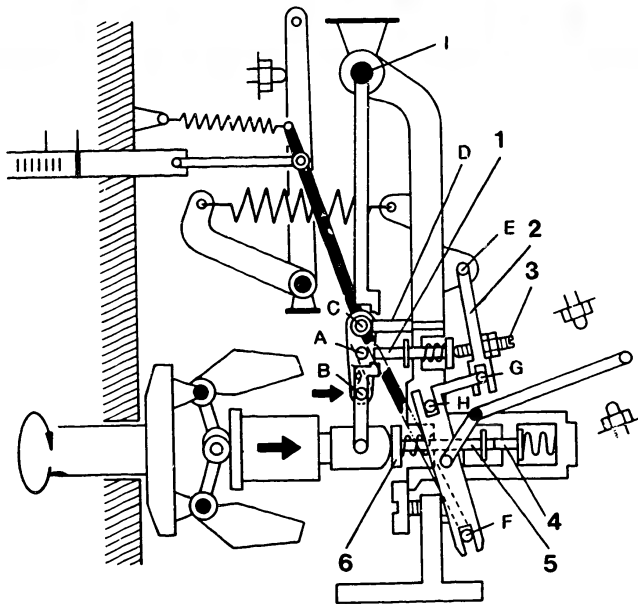
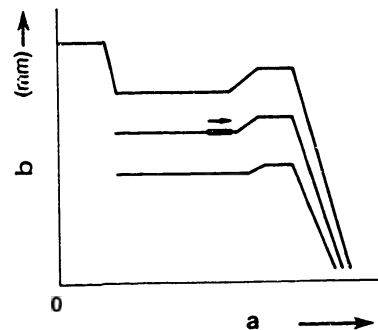

Fig. 61

- 1 = Pushrod
- 2 = Sub-lever
- 3 = Screw
- 4 = No. 2 Pushrod
- 5 = No. 1 Pushrod
- 6 = No. 1 Pushrod



- a = Pump speed (rpm)
- b = Control rack position

Partial Load Operation

When the load control lever moves from the idling position to the partial load position, the sub-lever rotates clockwise around fulcrum E. The pushrod is moved to the left by the screw.

When the pump speed increases and the No. 1 pushrod contacts the No. 2 pushrod, the increase lever's pin C also contacts the tension lever's pin D. Pivot pin A does not contact the pushrod.

E18

Additional devices
Governor RFD (K)

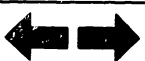

E19

Additional devices
Governor RFD (K)

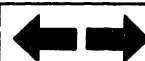

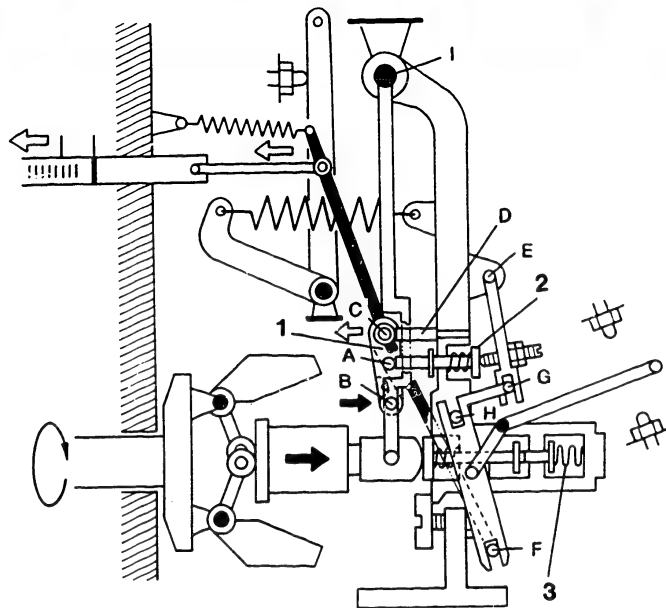
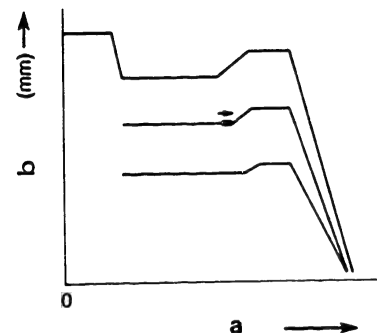

Fig. 62

- 1 = Increase lever
- 2 = Pushrod
- 3 = Torque control spring



- a = Pump speed (rpm)
- b = Control rack position

When the pump speed increases even further and the torque control spring is compressed, the increase lever rotates counter-clockwise around C and the pin at point A contacts the pushrod.

The position where fulcrum A and the pushrod come into contact varies because the position of the pushrod depends on the angle of the load control lever.

That is, the position where negative torque control starts to take effect varies.

E20

Additional devices
Governor RFD (K)



E21

Additional devices
Governor RFD (K)



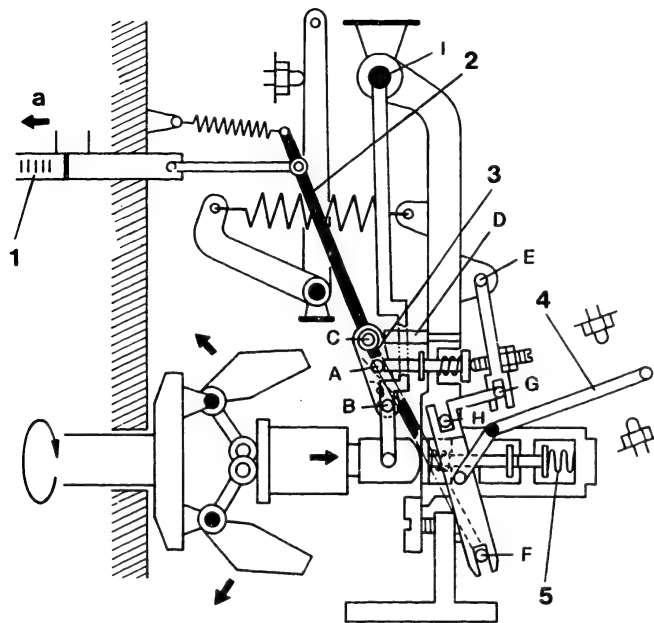

Fig. 63

- 1 = Control rack
- 2 = Floating lever
- 3 = Increase lever
- 4 = Load control lever
- 5 = Torque control spring
- a = Fuel-increase direction

When the pump speed increases further still and the torque control spring is compressed, the increase lever rotates counterclockwise around point A.

Point C, therefore, moves to the left, the floating lever rotates counterclockwise around point F and the control rack moves in the fuel-increase direction.

Thus, when the load control lever is at the partial load position, the speed at which torque control starts to take effect varies with the position of the load control lever (R_1 , R_2 , R_3) and the torque control stroke is changed.

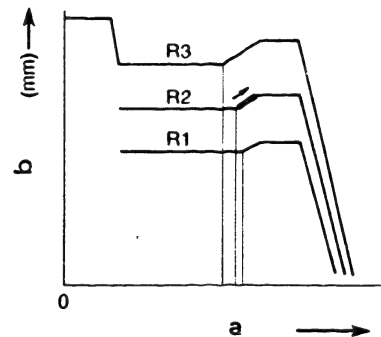

- a = Pump speed (rpm)
- b = Control rack position

E22

Additional devices
Governor RFD (K)



E23

Additional devices
Governor RFD (K)



SPECIAL TOOLS

For service of the RFD(K) type governor mounted on the PE(S).A(D) and PE(S).P Type pumps, the following special tools and general tools should be prepared.

Special Tools for Disassembly and Reassembly

Key No.	Part No.	Part Name	Q'ty	Remarks
1	KDEP 2919	Universal vise	1	
2	1 685 720 017	Bracket	1	For fixing PES.A(D) Type pumps (used together with universal vise: KDEP 2919)
3	KDEP 2963	Bracket	1	For fixing PE.A(D) Type pumps (used together with universal vise: KDEP 2919)
4	KDEP 2985	Bracket	1	For fixing PE.P Type pumps (used together with universal vise: KDEP 2919)
5	commerc. available	Ratchet handle	1	Used with socket wrenches
6	commerc. available	L-shaped handle	1	Used with socket wrenches
7	commerc. available	Socket wrench	1	For installing and removing the idling spring guide screw (SW 22 mm)
8	KDEP 2626	Wrench	1	For installing and removing the flyweight roundnut
9	KDEP 2918	Extractor	1	For removing the flyweight and coupling
10	KDEP 2624	Tappet holder	8	For supporting PE.A Type pump tappets (bolt type)
11	KDEP 2608	Tappet holder	6	For supporting PE.A Type pump tappets (shim type)
12	KDEP 2625	Tappet holder	6	For supporting PE.AD Type pump tappets (shim type)
13	KDEP 2638	Tappet holder	12	For supporting PE.P Type pump tappets (cam lift: 10 mm, 11 mm, 12 mm)
14	KDEP 2639	Wrench	1	For installing und removing SA.SCD Type timer mounting nuts (tooth width: 5.9 mm)

E24

Special tools
Governor RFD (K)

E25

Special tools
Governor RFD (K)



Special Tools for Disassembly and Reassembly (cont' d)

Key No.	Part No.	Part Name	Q'ty	Remarks
15	KDEP 2918	Extractor	1	For removing the flyweight and coupling
16	KDEP 2872	Extractor	1	For removing SA Type timing devices
17	KDEP 2640	Extractor	1	For removing timing devices
18	KDEP 2641	Extractor	1	For removing SP Type timing devices
19	KDEP 2642	Extractor	1	For removing SPM Type timing devices
20	KDEP 2965	Extractor	1	For removing SPGH Type timing devices
21	KDEP 2643	Extractor	1	For removing SCD and SAG Type timing devices
22	KDEP 2644	Extractor	1	For removing SCDM Type timing devices
23	KDEP 2906	Special wrench	1	For preventing camshaft rotation (slot width: 10 mm, 12 mm)
24	KDEP 2645	Special wrench	1	For preventing camshaft rotation
25	KDEP 2885	Special wrench	1	For preventing camshaft rotation
26	KDEP 2646	Special wrench	1	For preventing variable timing device rotation
27	KDEP 2647	Special wrench	1	For installing and removing SP Type timing device roundnuts (used with commerc. available tool)
28	KDEP 2648	Special wrench	1	For installing and removing SP Type timing device roundnuts (used with commerc. available tool)
29	commerc. available	Box wrench	1	For installing and removing SP Type timing device roundnuts
30	commerc. available	Box wrench	1	For installing and removing SP Type timing device roundnuts
31	KDEP 2649	Extractor	1	For removing SP Type timing devices
32	commerc. available	Socket wrench	1	SW 19 mm

E26

Special tools

Governor RFD (K)



E27

Special tools

Governor RFD (K)



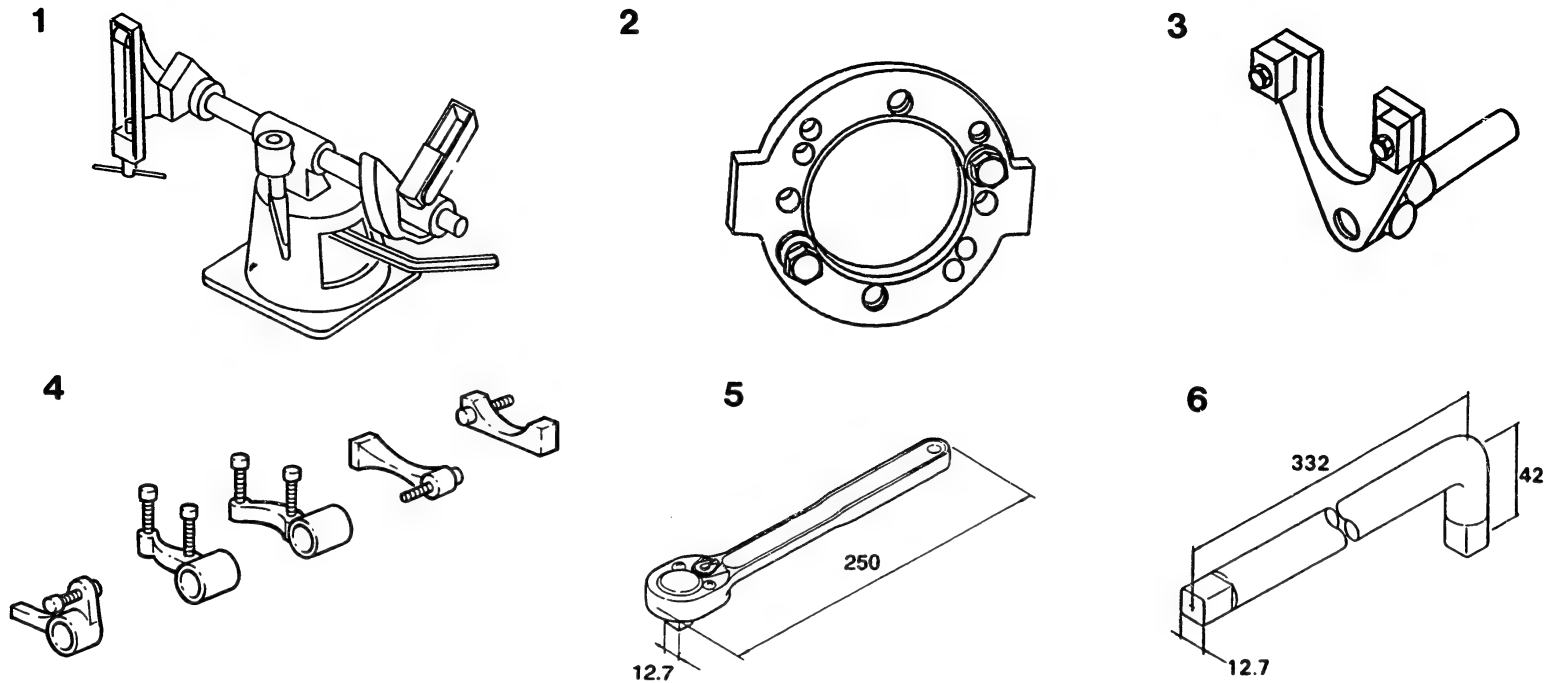

Fig. 64-1

Special Tools for Disassembly and Reassembly

- 1 = Universal vise
- 4 = Bracket

- 2 = Bracket
- 5 = Ratchet handle

- 3 = Bracket
- 6 = L-shaped handle

F1

Special tools
Governor RFD (K)



F2

Special tools
Governor RFD (K)

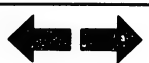

7

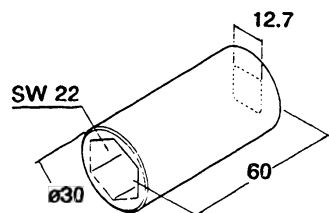

8

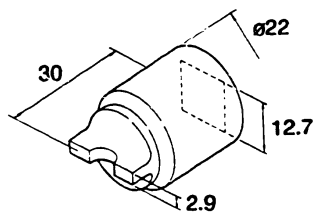

9

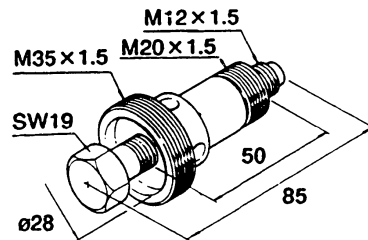

10

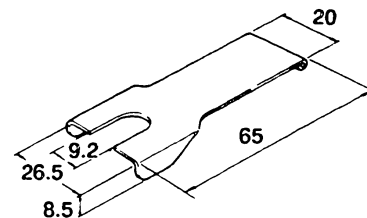

11

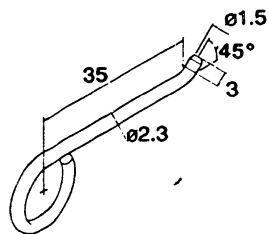

12

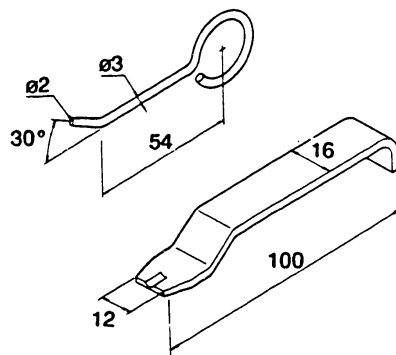

13

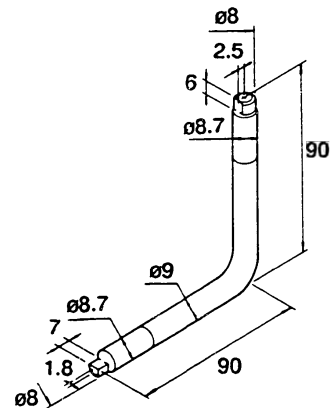

14

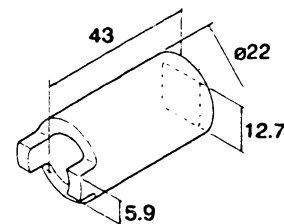

Fig. 64-2

Special Tools for Disassembly and Reassembly

7 = Socket wrench

8 = Wrench

9 = Extractor

10 = Tappet holder

11 = Tappet holder

12 = Tappet holder

13 = Tappet holder

14 = Wrench

F3

Special tools
Governor RFD (K)

F4

Special tools
Governor RFD (K)

15

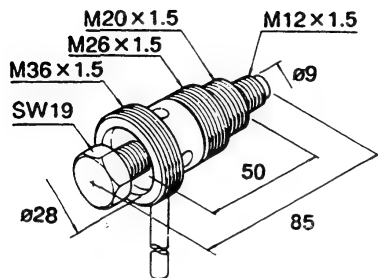

16

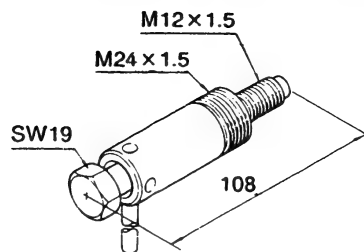

17

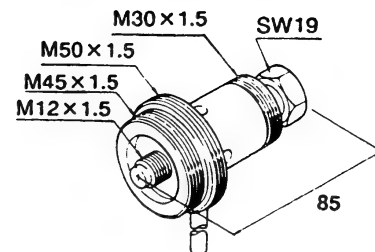

18

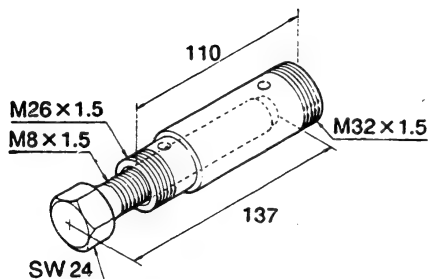

19

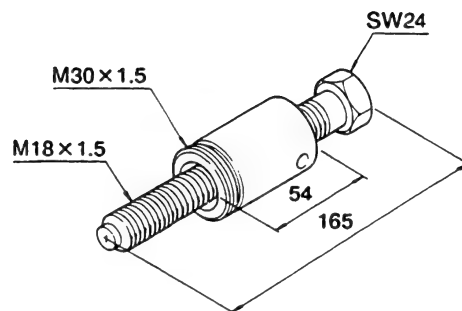

20

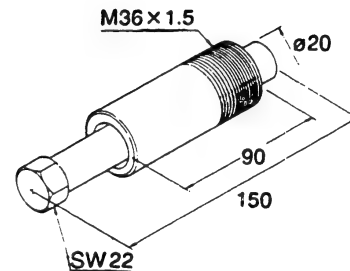

Fig. 64-3

Special Tools for Disassembly and Reassembly

15 = Extractor

16 = Extractor

17 = Extractor

18 = Extractor

19 = Extractor

20 = Extractor

F5

Special tools
Governor RFD (K)

F6

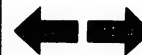
Special tools
Governor RFD (K)

21

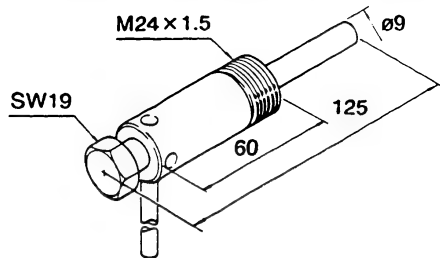

22

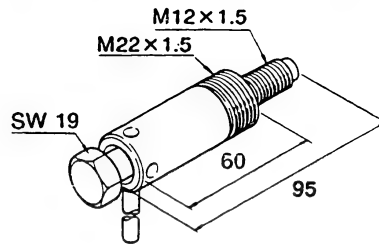

23

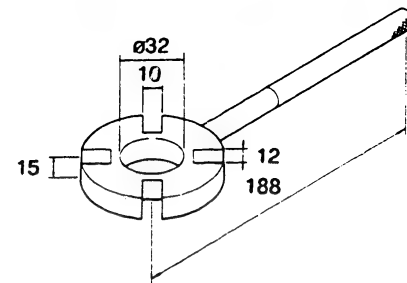

24

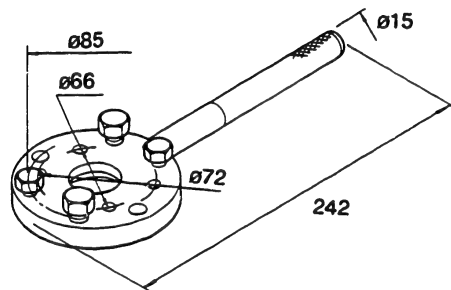

25

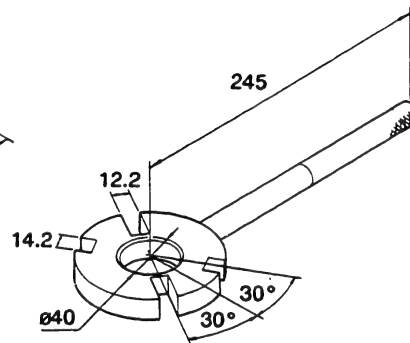

26

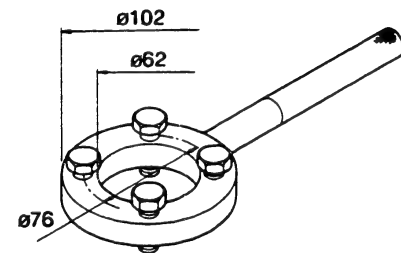

Fig. 64-4

Special Tools for Disassembly and Reassembly

21 = Extractor

22 = Extractor

23 = Special wrench

24 = Special wrench

25 = Special wrench

26 = Special wrench

F7

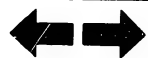
Special tools
Governor RFD (K)

F8

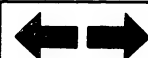
Special tools
Governor RFD (K)

27

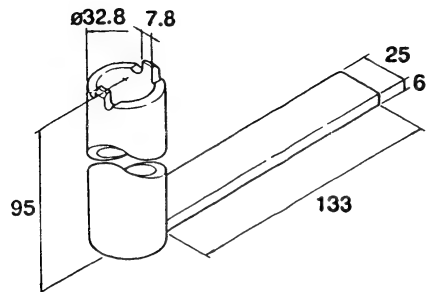

28

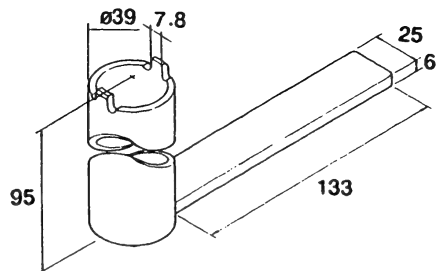

29

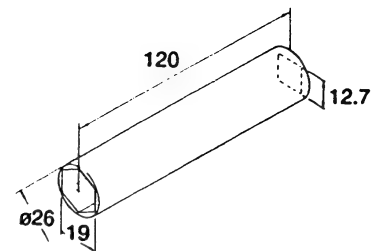

30

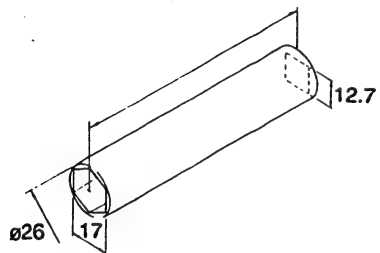

31

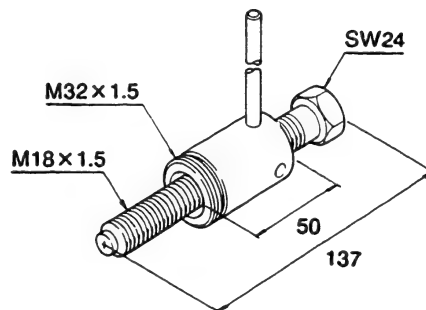

32

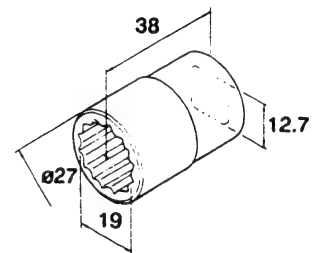

Fig. 64-5

Special Tools for Disassembly and Reassembly

27 = Special wrench

28 = Special wrench

29 = Box wrench

30 = Box wrench

31 = Extractor

32 = Socket wrench

F9

Special tools
Governor RFD (K)

F10

Special tools
Governor RFD (K)

Special Tools for Adjustment

Key No.	Part No.	Part Name	Q'ty	Remarks
1	1 688 901 013	Nozzle holder	12	Nozzle and nozzle holder assembly number is 1 688 801 000.
2	0 681 443 014	Nozzle	12	
3	1 680 750 008	Injection pipe	8	For PE(S).A(D) Type pumps Ø 2 x Ø 6 - 600 mm (M14 x 1.5; M14 x 1.5)
4	1 680 750 014	Injection pipe	8	For PE(S).A(D) Type pumps Ø 2 x Ø 6 - 600 mm (M14 x 1.5; M12 x 1.5)
5	1 680 750 015	Injection pipe	1	For PE(S).P Type pumps Ø 3 x Ø 8 - 600 mm (set of 12)
6	commerc. available	Wrench	1	For bleeding air from nozzle holders
7	1 688 030 044	Stand	2	For fixing PE.A, AD Type pumps
8	1 688 120 022	Clamping device	1	For fixing PE.A, AD Type pumps
9	1 688 010 129	Stand	1	For fixing PES Type pumps
10	1 680 202 005	Adapter	1	For fixing pumps (used together with key no. 11)
11	1 688 030 141	Stand	2	For fixing PE.P Type pumps
12	1 688 030 141	Stand	1	For fixing PES.P Type pumps
13	KDDC 0017	Flange	1	For fixing PES.P Type pumps (used together with key no. 19)
14	1 688 120 032	Stand	2	For fixing PE.P Type pumps
15	commerc. available	Lever	1	For operating test stand flywheels
16	1 686 430 022	Coupling	1	For driving pump (camshaft diameter: 17 mm)
17	1 686 430 024	Coupling	1	For driving pump (camshaft diameter: 20 mm)
18	1 686 430 026	Coupling	1	For driving pump (camshaft diameter: 25 mm)

F11

Special tools

Governor RFD (K)

F12

Special tools

Governor RFD (K)



Special Tools for Adjustment (cont' d)

Key No.	Part No.	Part Name	Q'ty	Remarks
19	commerc. available	Plug	1	Overflow pipe plug
20	commerc. available	Box spanner	1	For installing and removing injection pipes (SW: 17 mm)
21	commerc. available	Box spanner	1	For installing and removing injection pipes (SW: 19 mm)
22	1 688 130 130	Measuring device	1	Used for measuring PE.A Type pump control rack movement
23	1 688 130 130	Measuring device	1	Used for measuring PE(S).P Type pump control rack movement
24	1 688 130 130	Measuring device	1	Used for measuring PE(S).P Type pump control rack movement
25	1 687 000 061	Measuring device	1	Used for measuring PE(S).A(D), P Type pump control rack movement (used when measuring drive side boost compensator rack position)
26	1 688 130 130	Measuring device	1	Used for measuring PE(S).P Type pump control rack movement
27	1 688 130 183	Adjusting device	1	Used for fixing control lever
28	1 688 130 130	Measuring device	1	Used for measuring PE(S).A, AD Type pump control rack movement
29	KDEP 2605	Wrench	1	For adjusting torque control stroke (SW: 10 mm, screwdriver included)
30	KDEP 2604	Wrench	1	For adjusting idling spring (SW: 32 mm, tooth width: 3 mm)
31	KDEP 2650	Wrench	1	For adjusting torque control stroke (SW: 8 mm, screwdriver included)

F13

Special tools

Governor RFD (K)



F14

Special tools

Governor RFD (K)



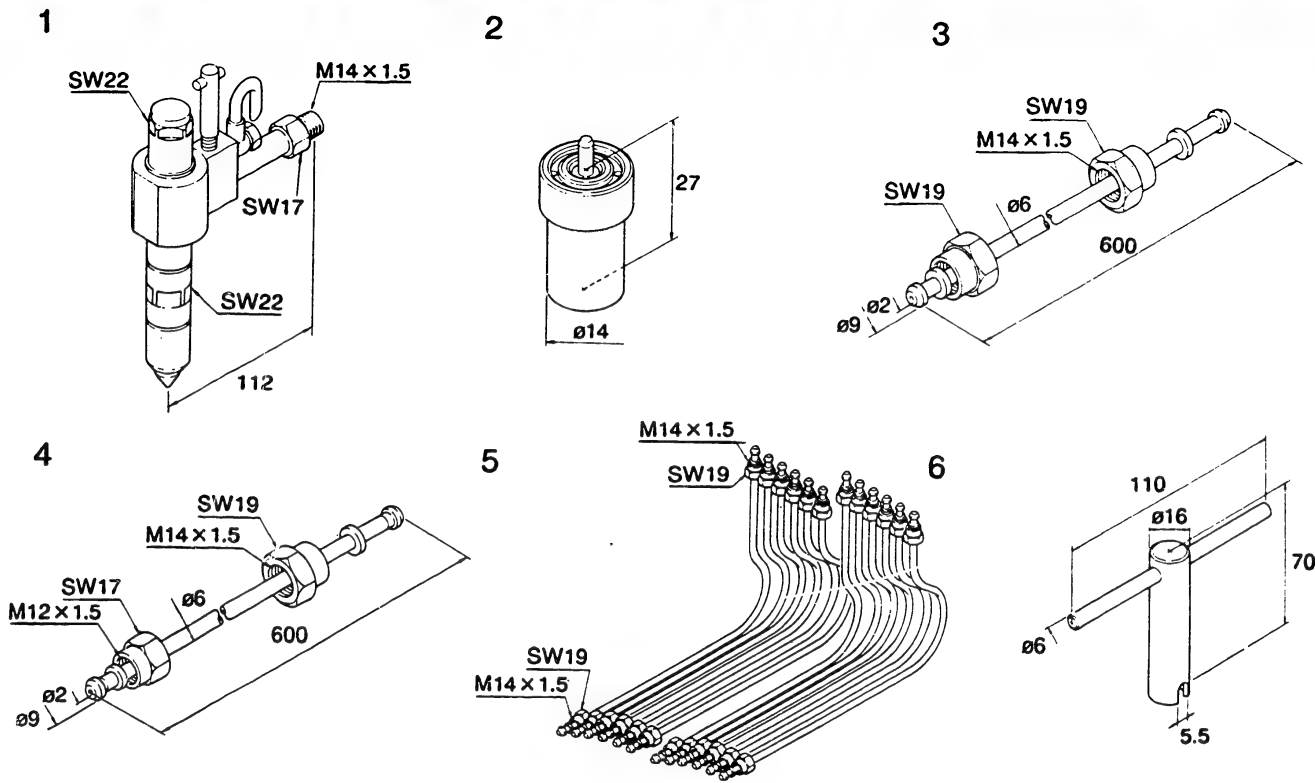

Fig. 65-1

- 1 = Nozzle holder
- 4 = Injection pipe

Special Tools for Adjustment

- 2 = Nozzle
- 3 = Injection pipe
- 5 = Injection pipe
- 6 = Wrench

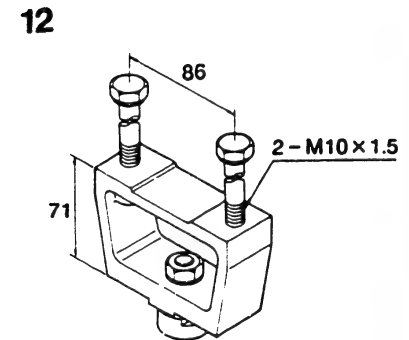
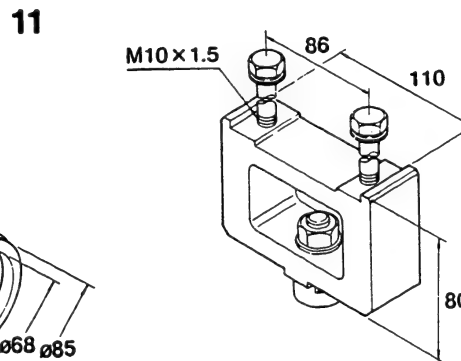
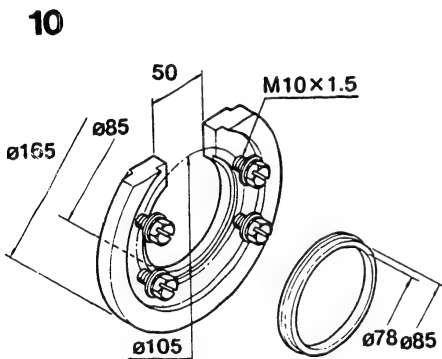
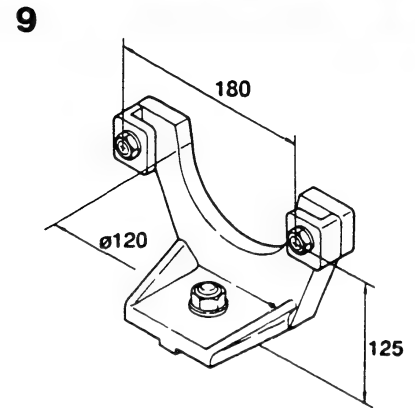
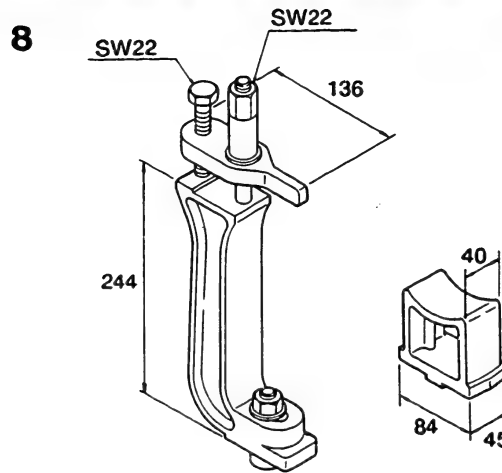
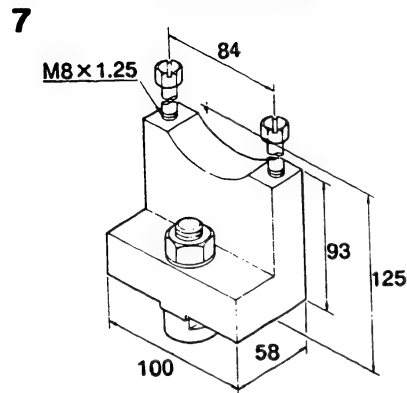

Fig. 65-2

7 = Stand
10 = Adapter

Special Tools for Adjustment

8 = Clamping device
11 = Stand

9 = Stand
12 = Stand

F17

Special tools
Governor RFD (K)



F18

Special tools
Governor RFD (K)

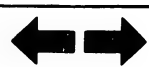

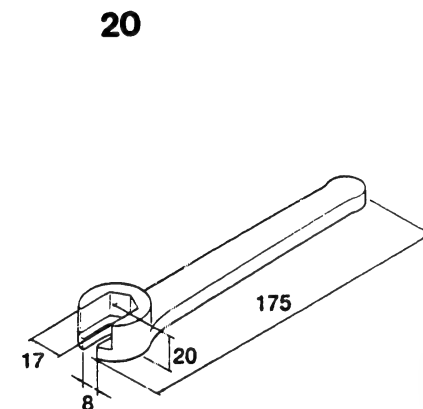
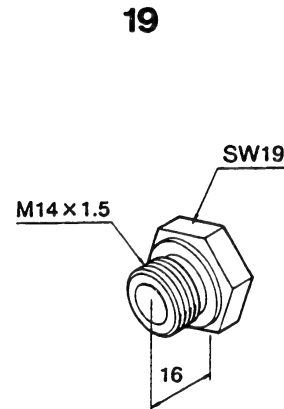
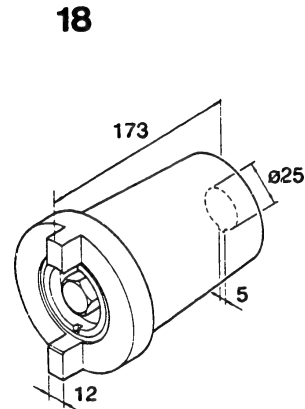
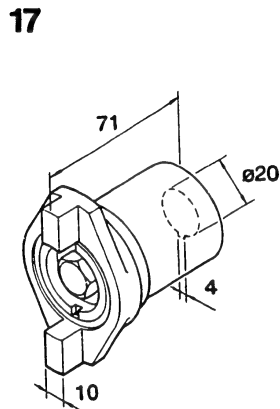
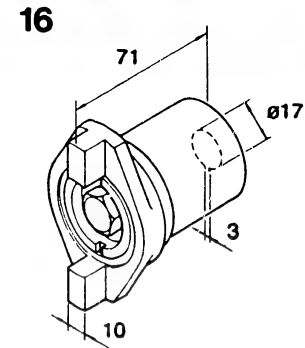
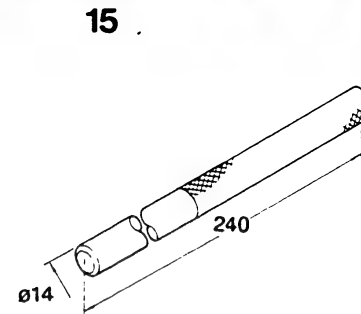
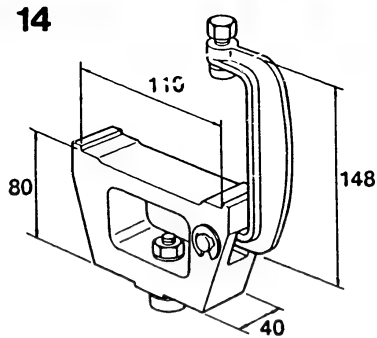
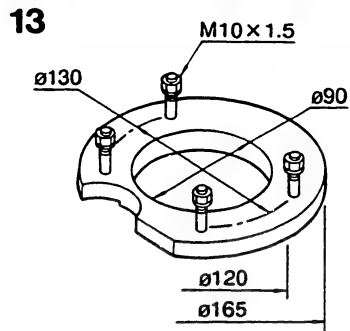

Fig. 65-3

Special Tools for Adjustment

13 = Flange
17 = Coupling

14 = Stand
18 = Coupling

15 = Lever
19 = Plug

16 = Coupling
20 = Box spanner

F19

Special tools
Governor RFD (K)



F20

Special tools
Governor RFD (K)

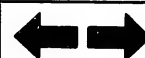

21

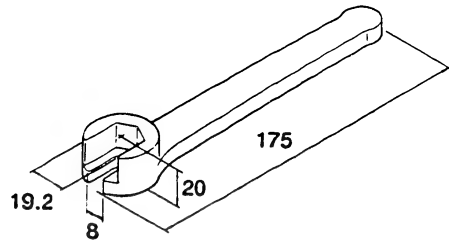

22, 23, 24

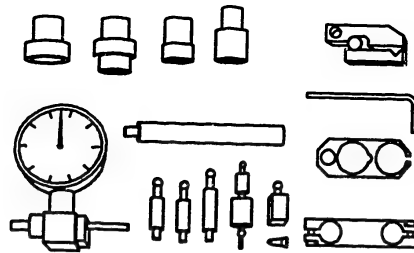

25

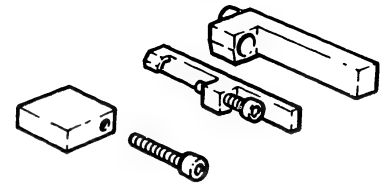

26

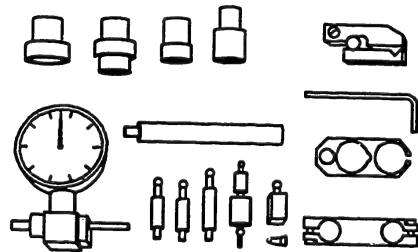

27

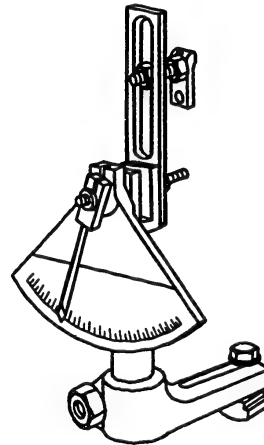

28

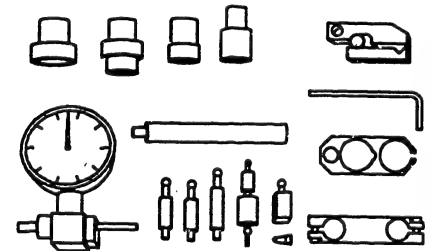

Fig. 65-4

21 = Box spanner

26 = Measuring device

Special Tools for Adjustment

22, 23, 24 = Measuring device

27 = Adjusting device

25 = Measuring device

28 = Measuring device

F21

Special tools
Governor RFD (K)

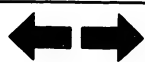

F22

Special tools
Governor RFD (K)

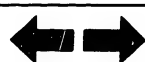

29

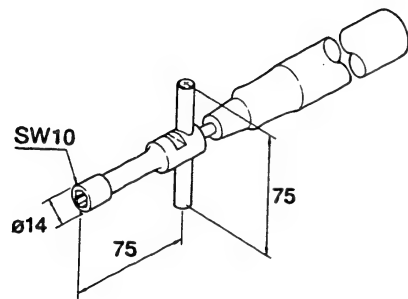

30

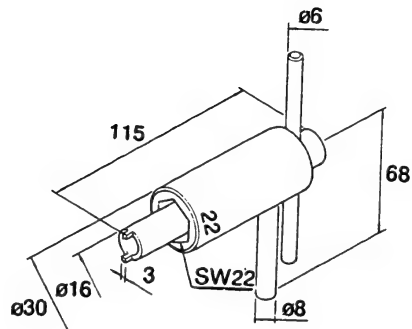

31

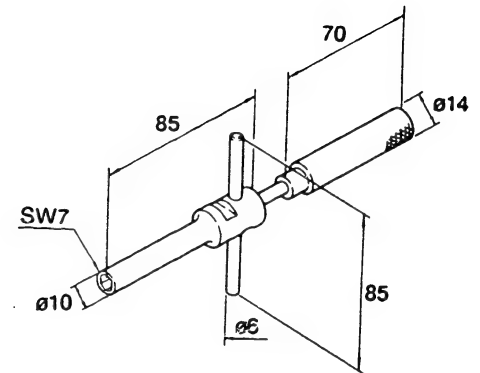

Fig. 65-5

Special Tools for Adjustment

29 = Wrench

30 = Wrench

31 = Wrench

F23

Special tools
Governor RFD (K)



F24

Special tools
Governor RFD (K)



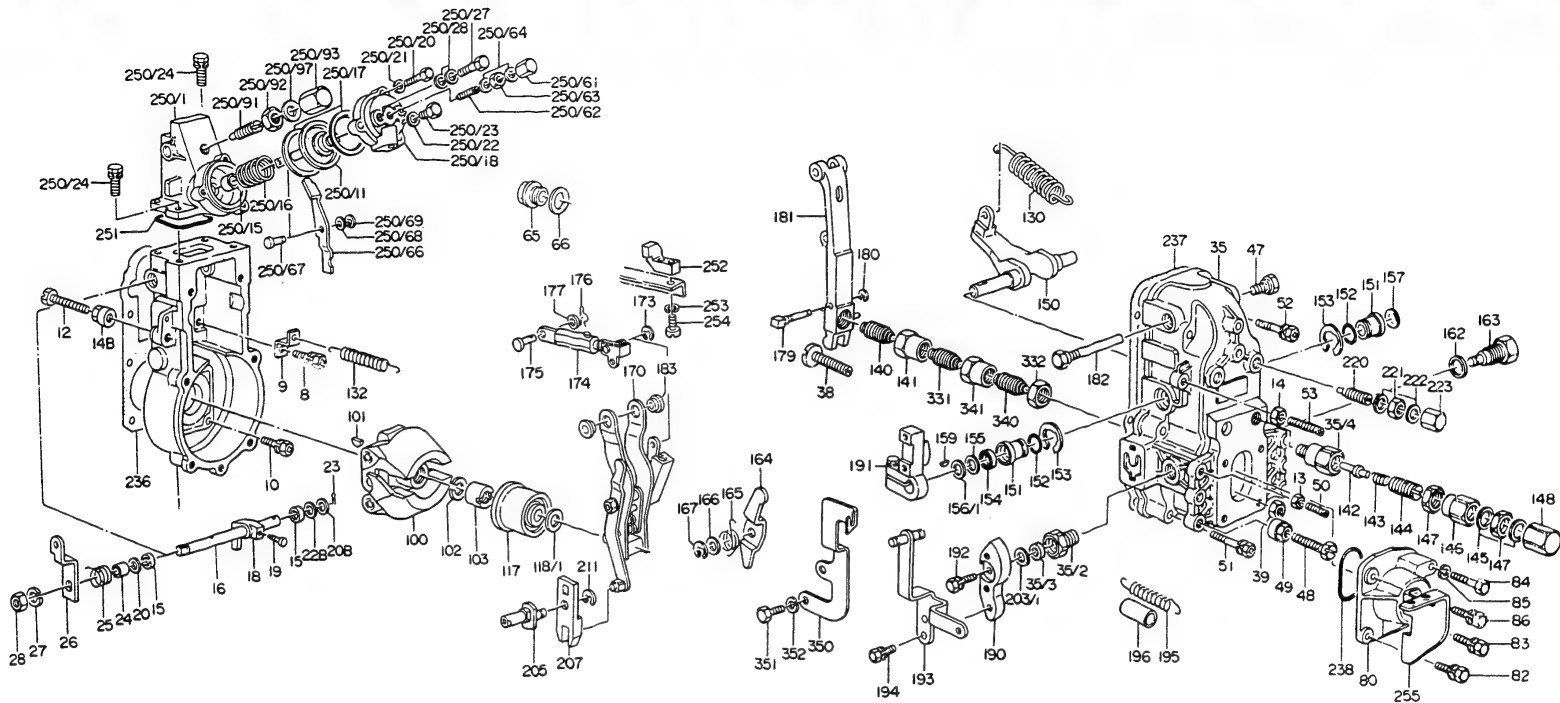

Fig. 66-1

RFD Type governor with the governor side B.C.S.

EXPLODED VIEWS

F25	Exploded views
	Governor RFD (K)



F26	Exploded views
	Governor RFD (K)



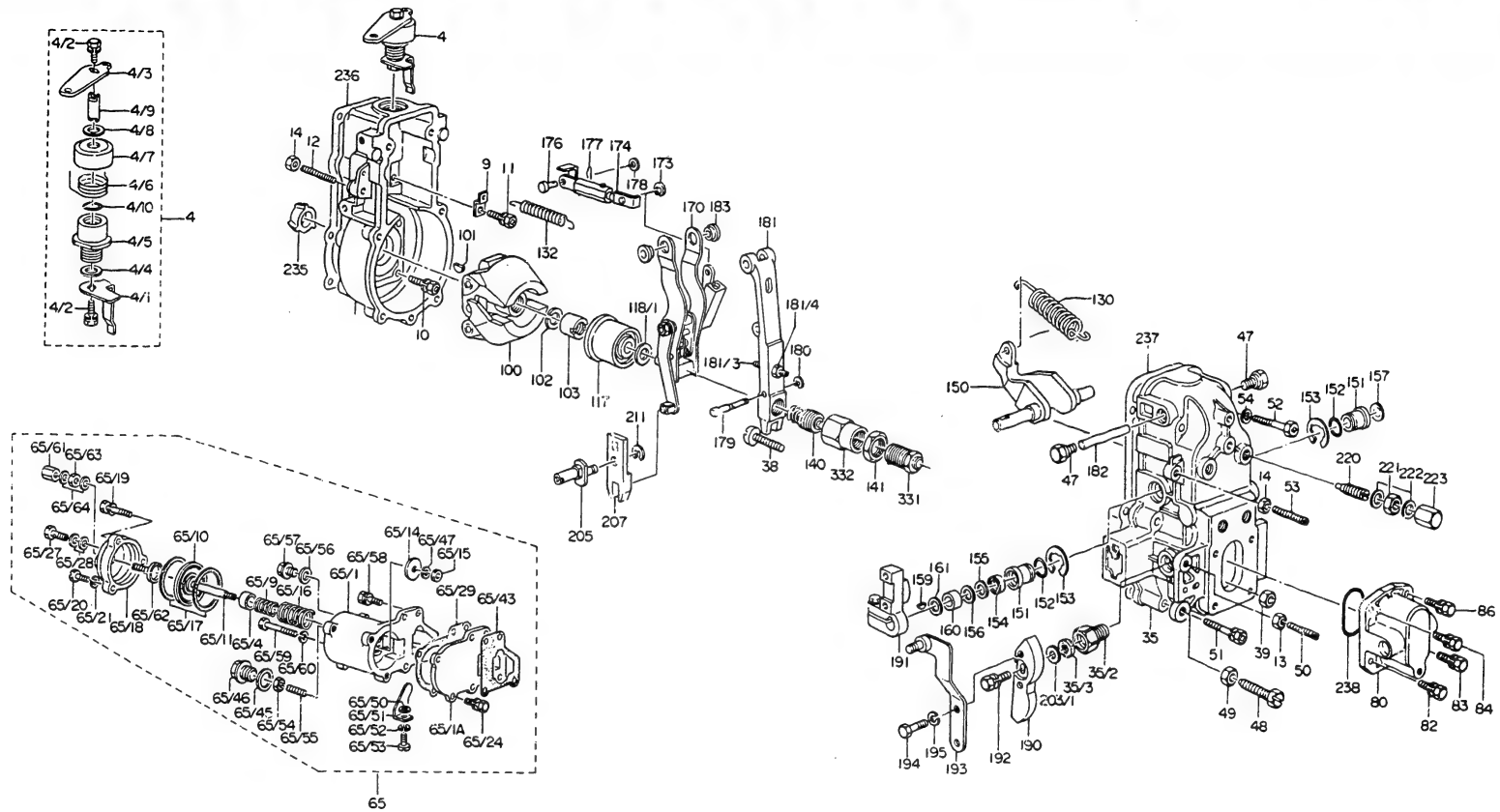

Fig. 66-2

RFD-K Type governor with the governor side B.C.S.

Exploded views

F27

Exploded views
Governor RFD (K)



F28

Exploded views
Governor RFD (K)



DISASSEMBLY

Before disassembling the RFD(K) Type mechanical governor, wipe off all dirt, etc., adhering to the outside and carefully clean the work bench where the work will be performed. Careful arrangement of the parts removed will make reassembly faster and easier.

Also record the performance of the mechanical governor and the positions of the adjustable parts before starting disassembly. This data can be useful for discovering the causes of any problems which might occur after adjustments have been made.

The numbers in brackets following part names are the numbers of the parts as listed in the exploded view, and the numbers in brackets following tool names are the part numbers of the tools listed.

The following descriptions of disassembly, inspection and reassembly are based on the PE:P Type pump equipped with the RFD Type mechanical governor and SAG timing device.

G1

Disassembly

Governor RFD (K)



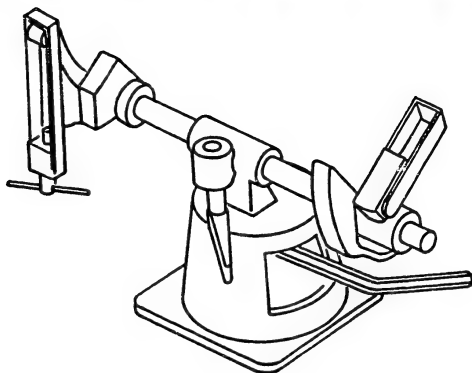

Fig. 67 Mounting the bracket

Preparation

1. Mount the bracket (KDEP 2985) in the universal vise (KDEP 2919).



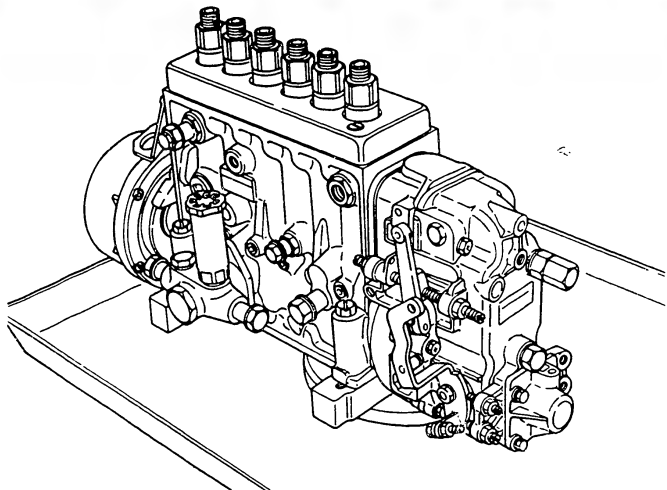

Fig. 68 Attaching the injection pump

2. Use four bolts to fasten the pump securely to the bracket.



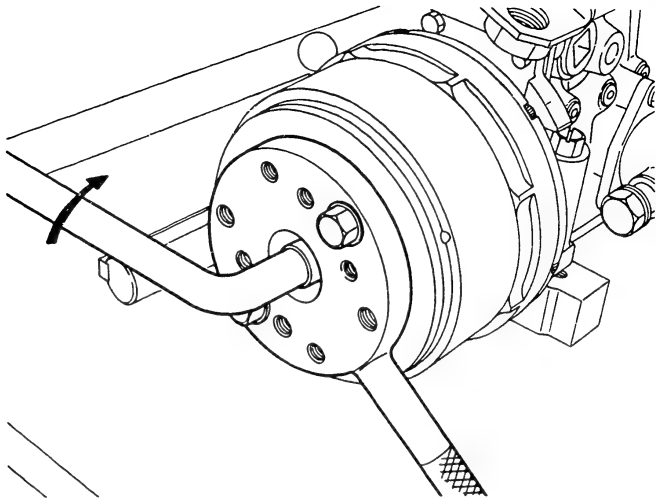

Fig. 69 Removing the timing device mounting nuts

3. Use the wrench (KDEP 2639) to remove the timing device mounting nuts, and the spanner (KDEP 2645) to prevent camshaft rotation.

Note: When the timing device is provided with a laminated coupling, remove this first using a spanner.



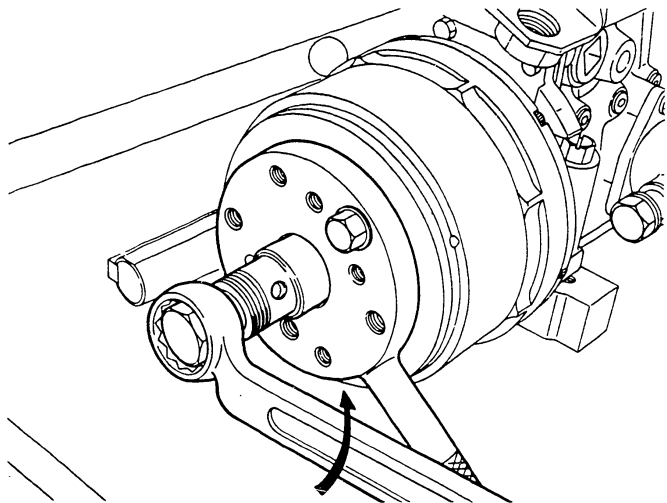

Fig. 70 Removing the timing device

4. Use the extractor (KDEP 2643) to remove the timing device from the camshaft.

G5

Disassembly
Governor RFD (K)



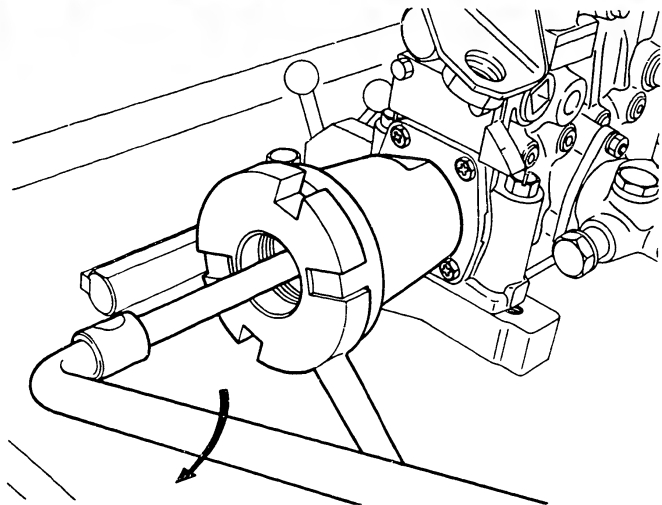

Fig. 71 Attaching the coupling

5. Attach the coupling (1 686 430 026) to the drive side of the camshaft.
Use the spanner (KDEP 2906) to prevent camshaft rotation.

G6

Disassembly

Governor RFD (K)



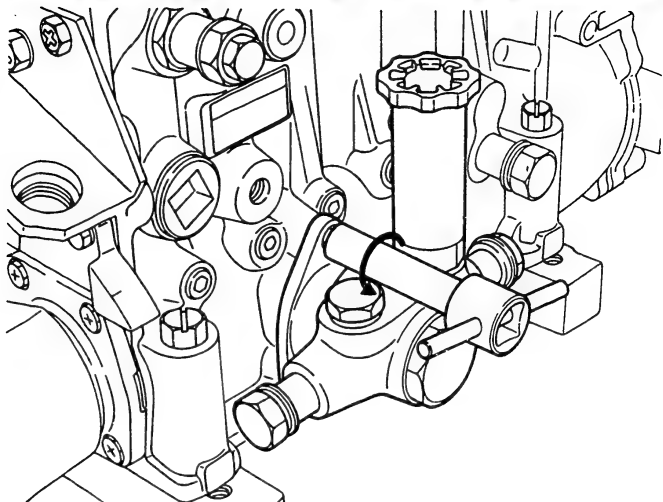

Fig. 72 Removing the supply pump

6. Use a spanner (SW: 10mm) to loosen the supply pump mounting nuts and then remove the supply pump.

G7

Disassembly
Governor RFD (K)



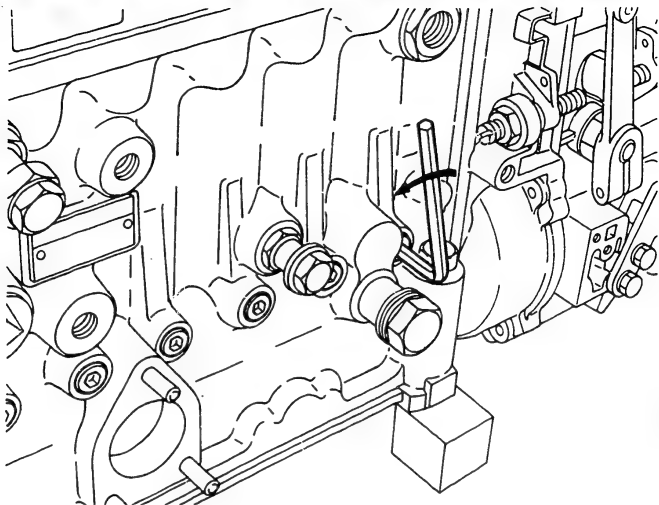

Fig. 73 Removing the plug

7. Use the hexagon wrench (M 6) to remove the plug mounted on the side of the pump housing.

Note: With PE-A Type pumps, remove the cover attached to the front.



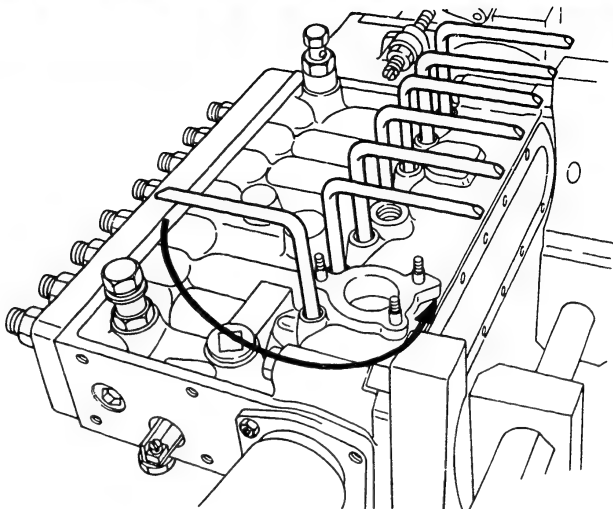

Fig. 74 Inserting the tappet holders

8. Use the spanner (KDEP 2906) to hold the tappets at top dead center. Insert the tappet holders (KDEP 2638) in sequence, starting from the governor side. Do not allow the tappets to contact the camshaft.

Note: For PE-A Type pumps, insert the tappet holders in the injection sequence.



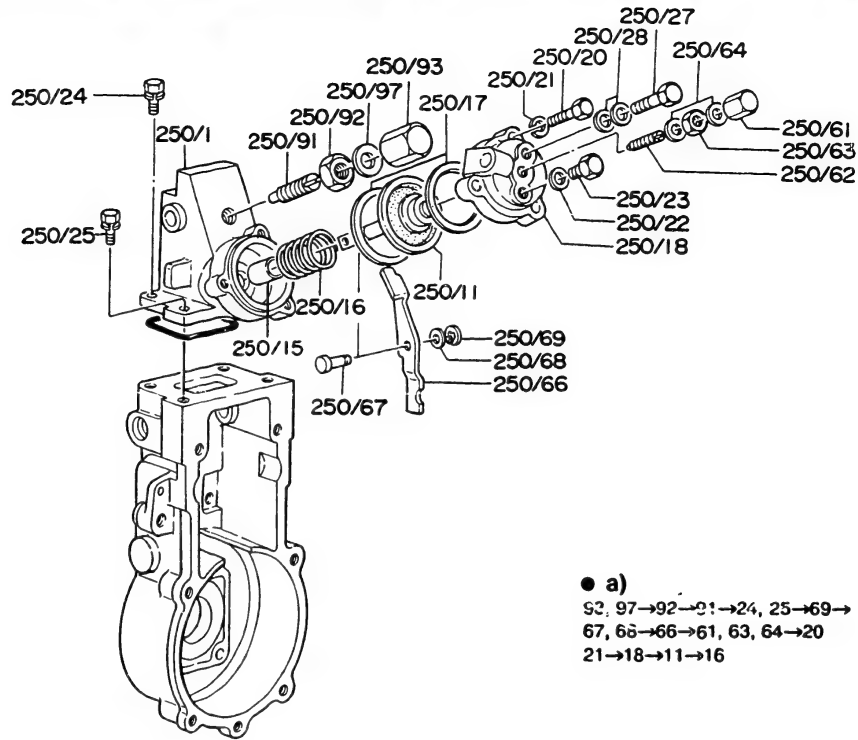

Fig. 75 Exploded view of governor side B.C.S.

● a) Disassembly sequence

Governor Side Boost Compensator Disassembly

Figure 75 shows the disassembly sequence for the governor side boost compensator. The disassembly procedure is described on the following pages.

G10

Disassembly
Governor RFD (K)

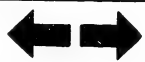

G11

Disassembly
Governor RFD (K)



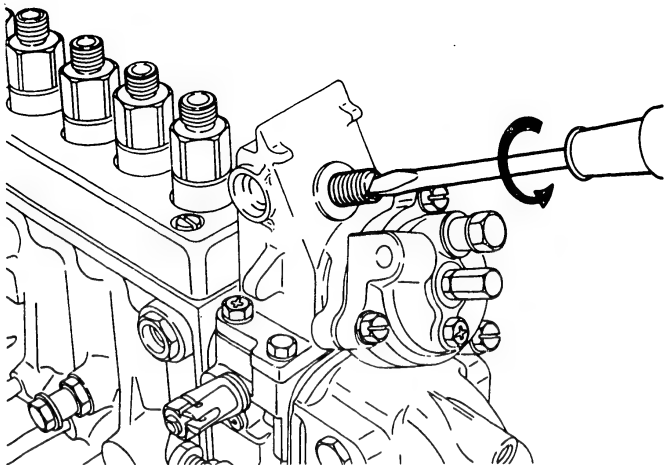

Fig. 76 Removing the rack position adjustment screw

1. Use a spanner (SW: 17mm) to remove the cap nut (250/93).
2. Use a screwdriver to remove the rack position adjustment screw (250/91) (refer to Fig. 76).



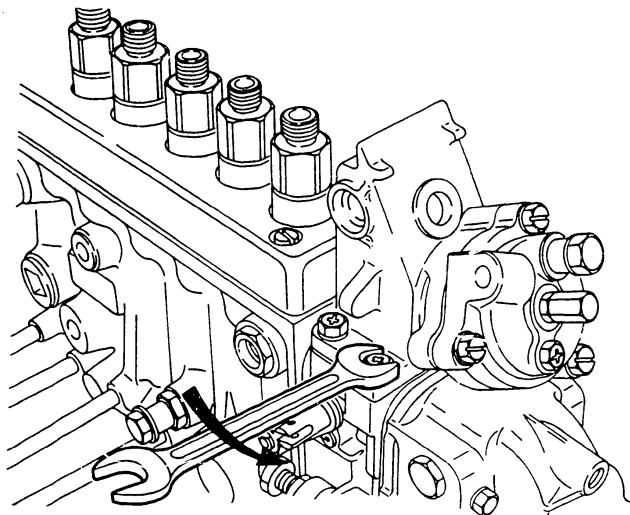
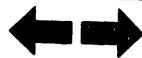

Fig. 77 Removing the four bolts

3. Use a spanner (SW: 10mm) to remove the four bolts (250/24, 25), and then remove the boost compensator assembly.



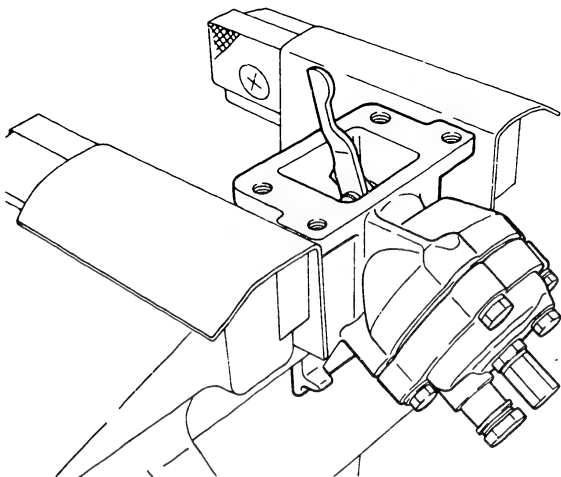

Fig. 78 Fixing the B.C.S.

4. Fix the boost compensator in a vise as shown in Figure 78.

Note: Use relatively soft brass plates when fixing the boost compensator assembly in the vise.



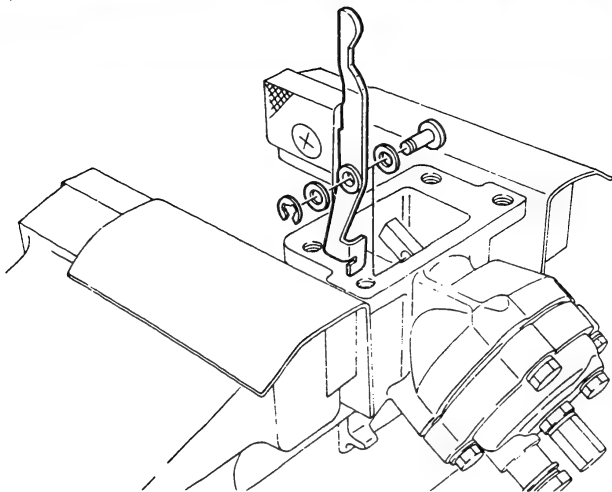
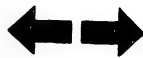

Fig. 79 Removing the B.C.S. lever

5. Remove the snapping (250/69) and pin (250/67), and then remove the boost compensator lever (250/66) from the pushrod.



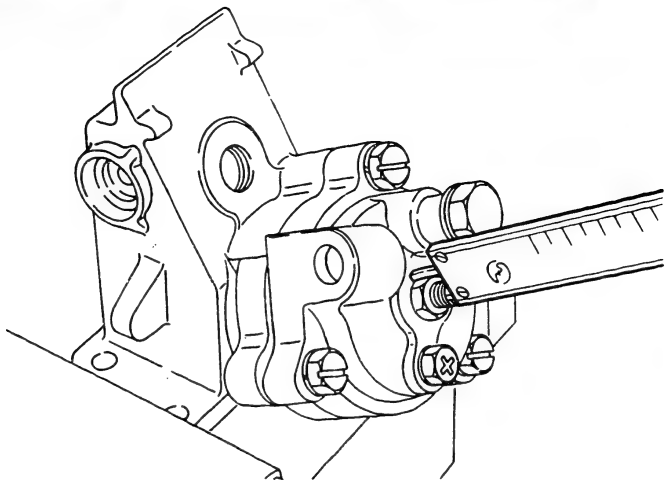

Fig. 80 Measuring the screw/cover distance

6. Before removing the cover (250/18), remove the cap nut (250/61) and measure the distance between the tip of the screw (250/62) and the end of the cover.

G16

Disassembly

Governor RFD (K)



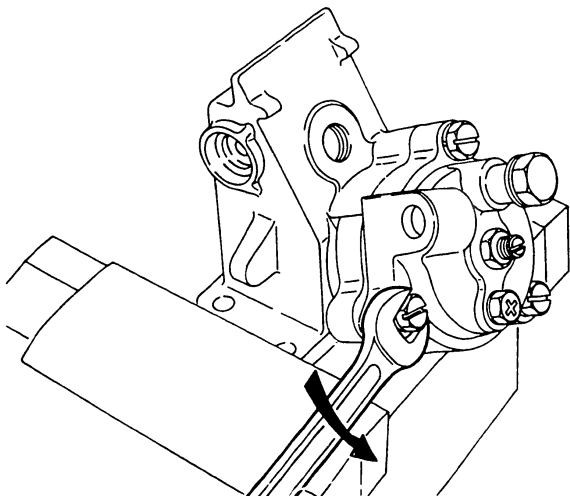

Fig. 81 Loosening the bolt

7. Use a spanner (SW: 10mm) to loosen the bolt (250/20), and then remove the cover.

G17

Disassembly
Governor RFD (K)



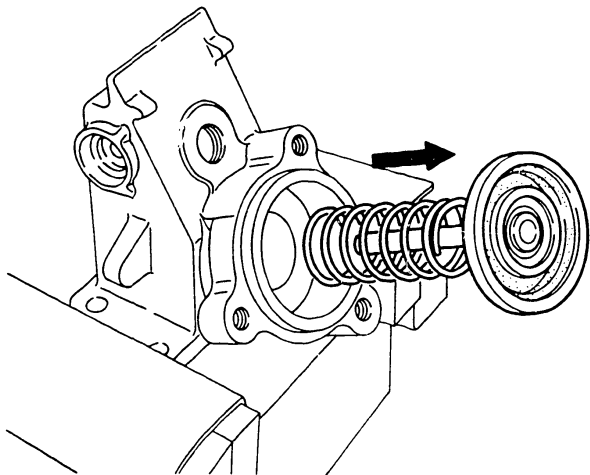
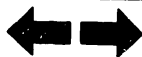
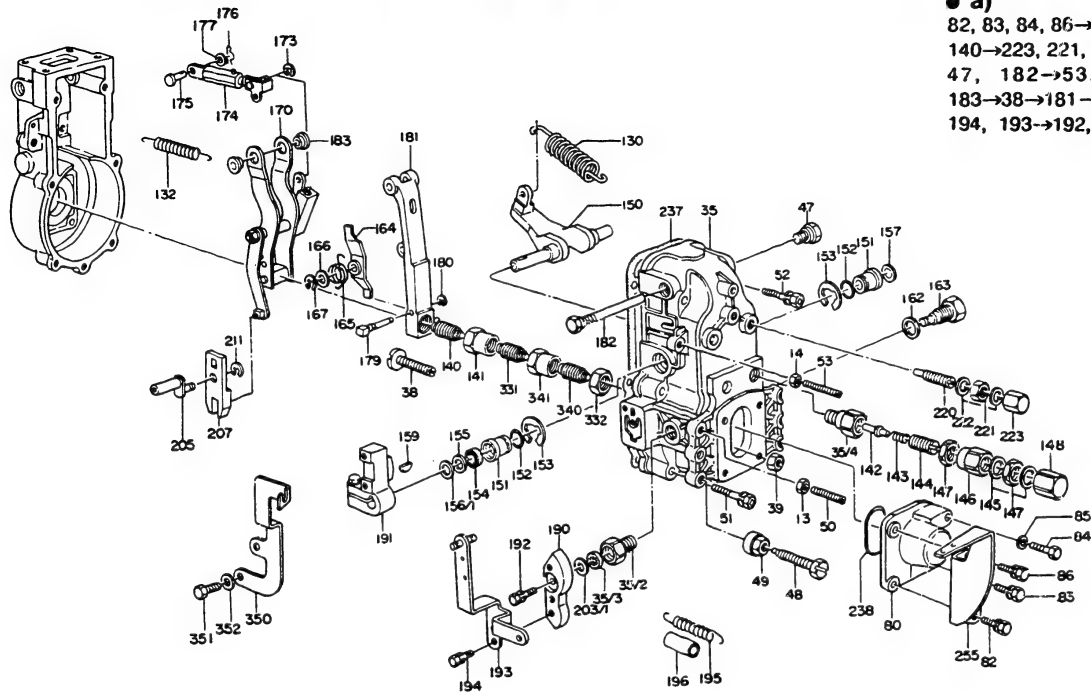

Fig. 82 Removing the diaphragm and
B.C.S. spring

8. Remove the diaphragm (250/11) and boost compensator spring (250/16) from the boost compensator housing.





- a)
- 82, 83, 84, 86→80, 255→332→340→341→331→141→
- 140→223, 221, 222, 220→144 (b)→
- 47, 182→53, 14→51, 52→35→47, 182→170,
- 183→38→181→191, 159, 156, 155→153→151→150→
- 194, 193→192, 190→205, 207→167, 166, 165, 164

Fig. 83

- a) = Disassembly sequence
- (b)→Torque spring assembly

Governor Cover Disassembly

Figure 83 shows the disassembly sequence for the governor cover. The disassembly procedure is described on the following pages.

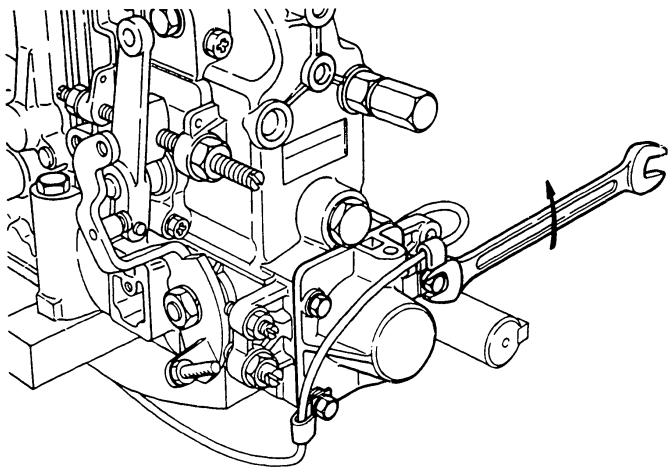

Fig. 84 Loosening the bolt

1. Use a spanner (SW: 10mm) to loosen the bolt (82) and remove the closing cover (80) at the end of the governor cover.



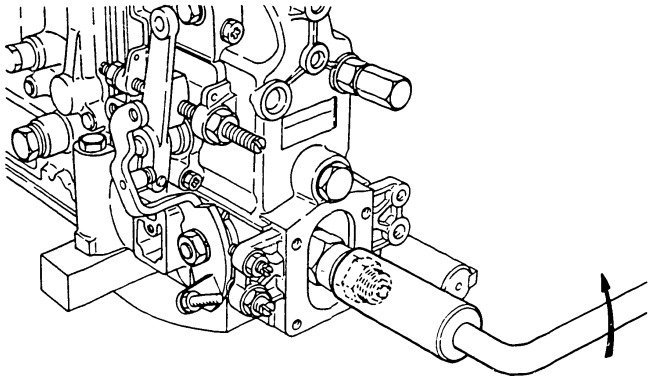

Fig. 85 Loosening the locknut

2. Use a socket wrench (SW22) to loosen the locknut (332). Then, remove it together with the No. 2 torque control spring (340).

Note: Use this procedure only when torque control springs are provided.



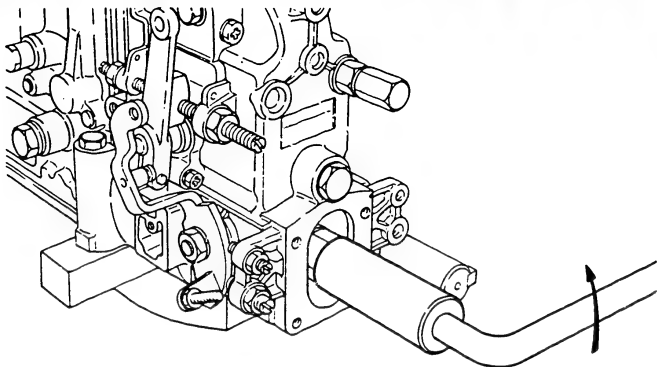

Fig. 86 Loosening the guide screw

3. Use a socket wrench (SW22) to loosen the guide screw (341) before removing it together with the No. 1 torque control spring (331).

Note: Use this procedure only when torque control springs are provided.



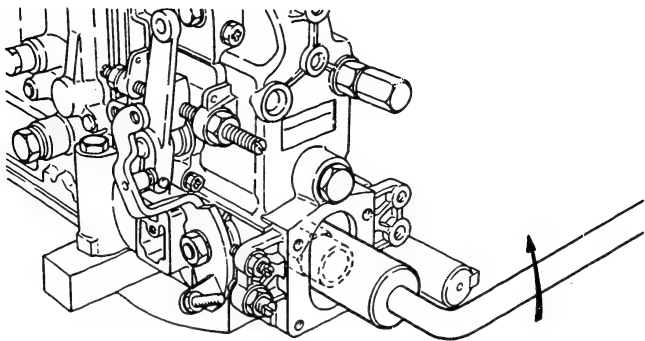

Fig. 87 Loosening the guide screw

4. Use a socket wrench (SW22) to loosen the guide screw (141), and then remove it together with the idling spring (140).



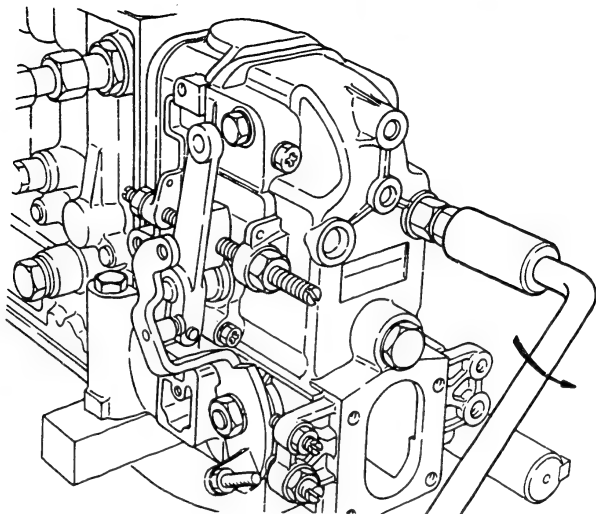

Fig. 88 Loosening the locknut

5. Use a socket wrench (SW: 17mm) to loosen the cap nut (223) and locknut (221). Then, remove the damper spring (220).



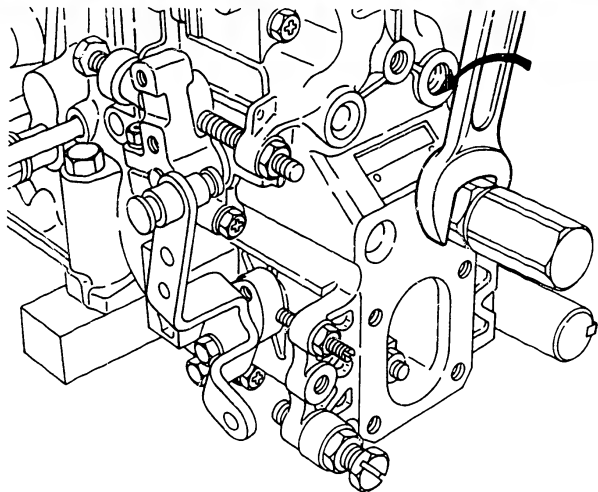

Fig. 89 Removing the torque spring assembly

6. Use a spanner (SW: 27mm) to remove the torque spring assembly (144).



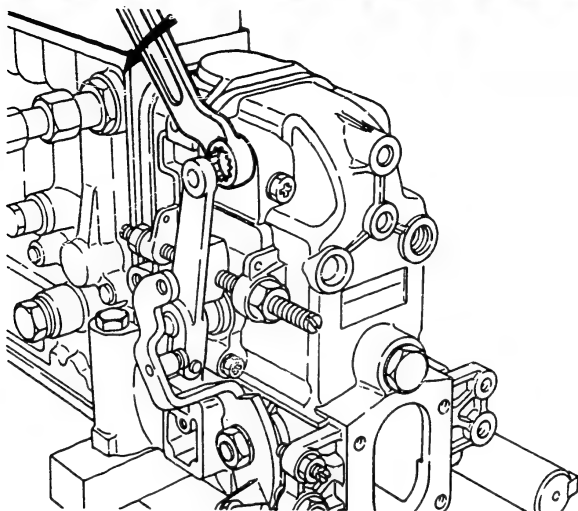

Fig. 90 Loosening the two plugs

7. Use a wrench (SW: 14mm) to loosen the tension lever shaft plug (47).

Note: The above operation facilitates disassembly of the tension lever after the governor cover is removed.



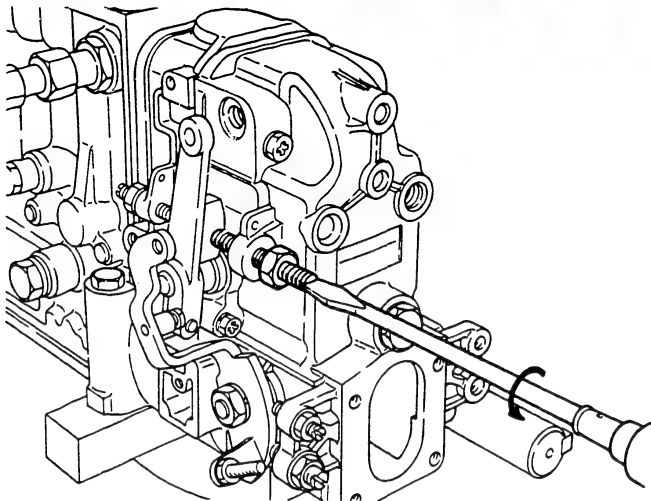

Fig. 91 Loosening the screw

8. Use a spanner (SW: 12mm) to loosen the locknut (14).
Next, loosen the screw (53) to release the tension of the governor spring.



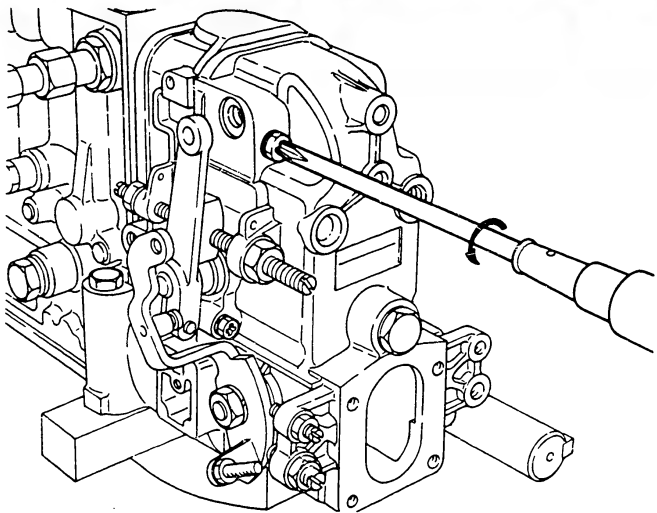

Fig. 92 Loosening the six bolts

9. Use a philips head screwdriver to loosen the six bolts (51, 52) fastening the governor cover.

H1

Disassembly

Governor RFD (K)



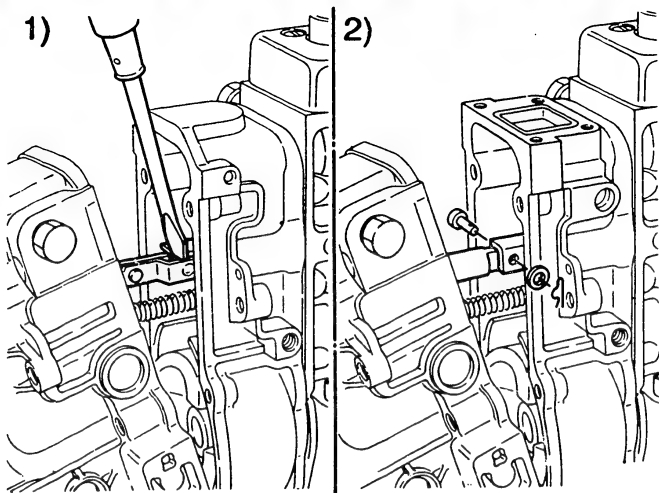

Fig. 93 Removing the governor cover

10. Remove the governor cover (35) from the governor housing (1).
- 1) For standard governors, the connection between the control rod and link (174) can be broken by pressing down on the flat spring of the link (174) with a screwdriver.
- 2) When the governor is equipped with a boost compensator, the connection between the control rod and link (174) can be broken by removing the split pin (176) and pin (175).



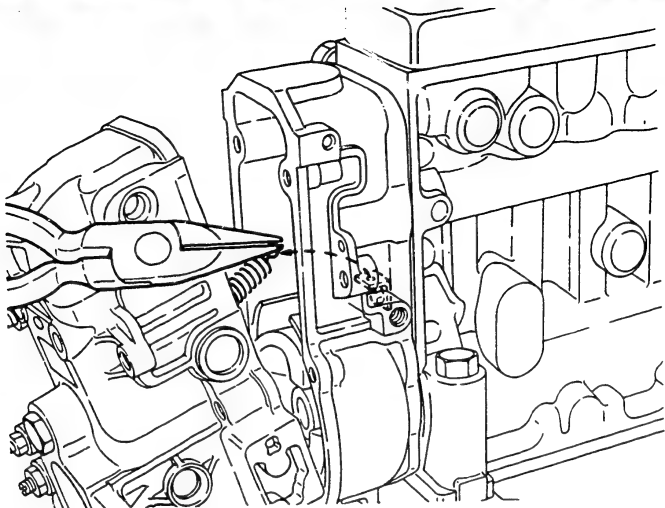

Fig. 94 Removing the start spring

- 3) The start spring (132) is attached to the spring eye (9). Use pliers to remove the hook of the spring from the spring eye.



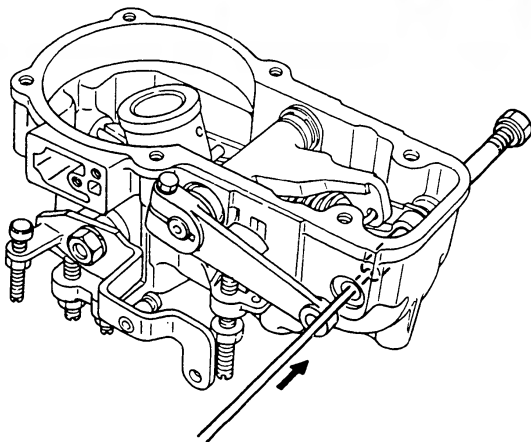

Fig. 95 Pulling out the tension lever shaft

11. Remove the plug (47) and pull out the tension lever shaft (182).

H4

Disassembly
Governor RFD (K)



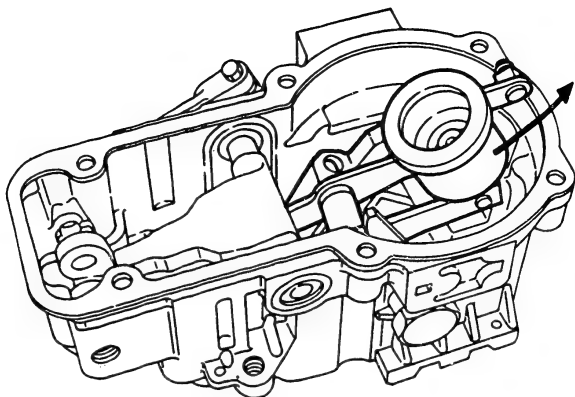

Fig. 96 Pulling out the guide lever assembly

12. Pull out the guide lever assembly (170) from the bottom of the governor cover.

Note: Take care not to lose the two collars (183) installed at the top of the guide lever.



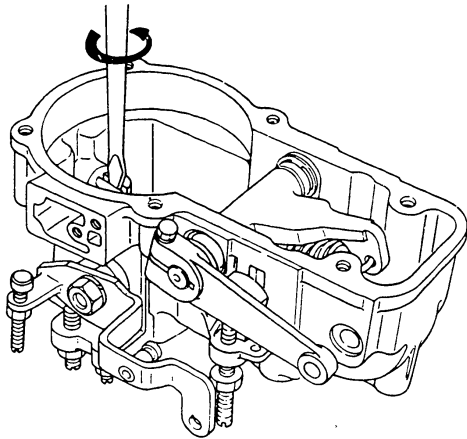

Fig. 97 Removing the stroke adjusting screw

13. Remove the stroke adjusting screw (38).

H6

Disassembly
Governor RFD (K)



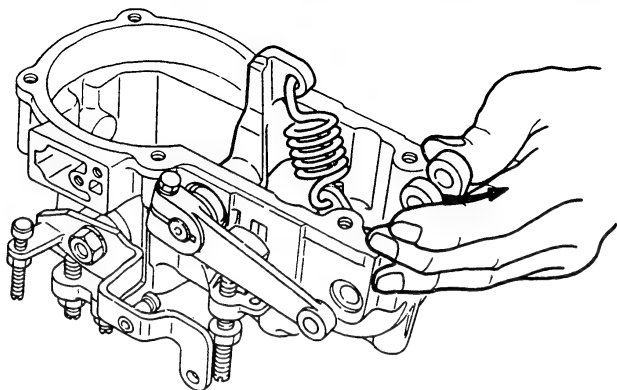

Fig. 98 Pulling out the tension lever

14. Separate the tension lever (181) and governor spring (130). Then, pull out the tension lever from the top of the governor cover.

H7

Disassembly
Governor RFD (K)



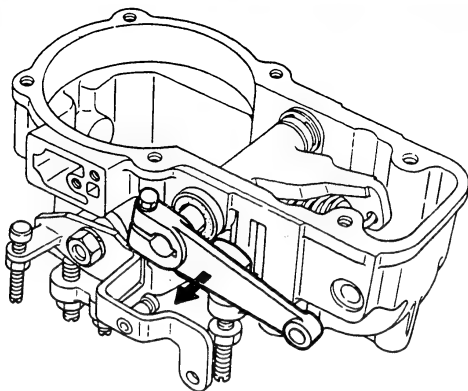

Fig. 99 Removing the speed control lever

15. Loosen the bolt (SW: 12mm) and remove the speed control lever (191), key (159), washer (155) and shim (156).



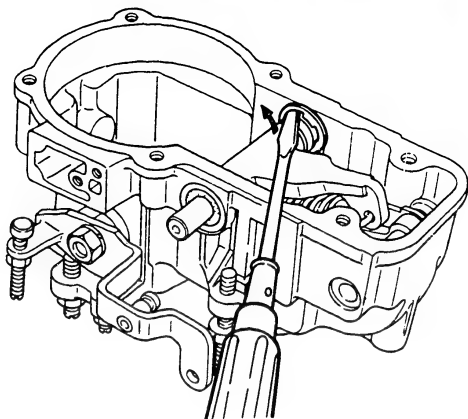
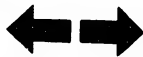

Fig. 100 Removing the two snaprings

16. Use a screwdriver to remove the two snaprings (153).

H9

Disassembly
Governor RFD (K)



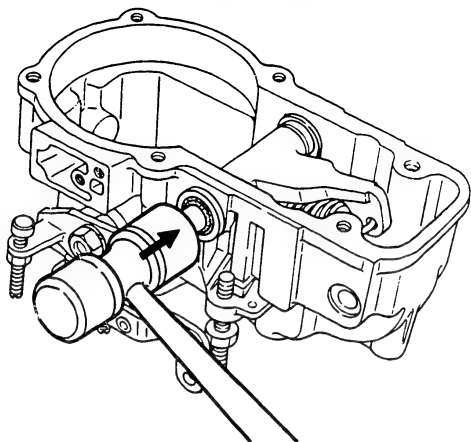

Fig. 101 Removing the two bushes

17. Use a plastic hammer to remove the two bushes (151) by tapping lightly on the end of the speed setting lever (150).
18. Remove the governor spring (130) from the speed setting lever (150).



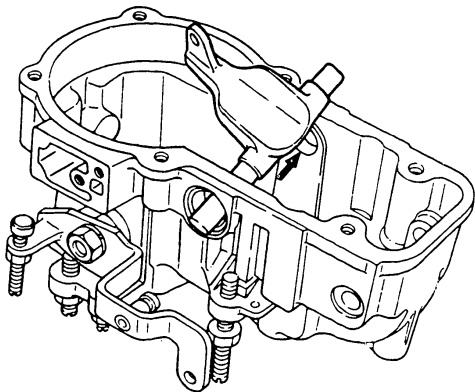

Fig. 102 Removing the speed setting lever

19. Remove the speed setting lever (150) from the governor cover.

H11

Disassembly
Governor RFD (K)



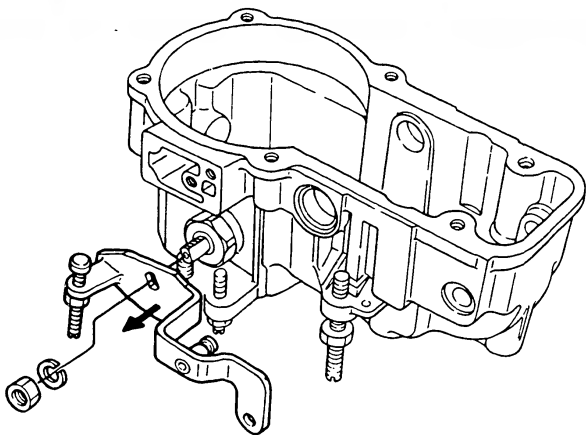

Fig. 103 Removing the load control lever

20. With a single-piece type load control lever, use a spanner (SW: 10mm) to remove the nut (192) and the load control lever.



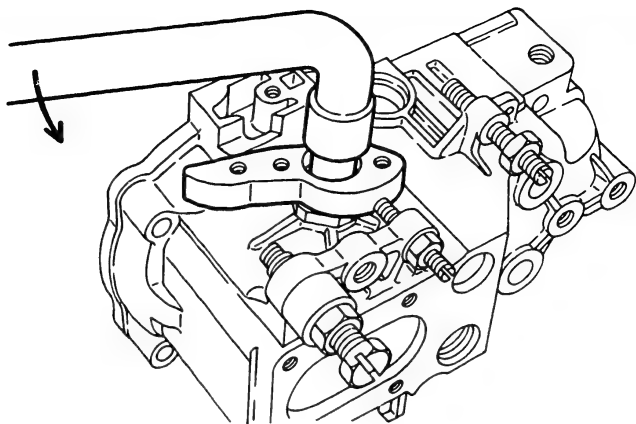

Fig. 104 Removing the load control lever

21. With a separate-type load control lever, remove one control lever (193) first, and then use a spanner (SW: 10mm) to loosen the bolt (192) and remove the other control lever (190).



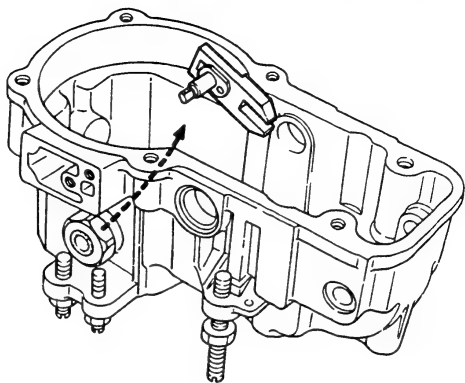

Fig. 105 Removing the eccentric shaft and supporting lever

22. Remove the eccentric shaft (205) and supporting lever (207) as an assembly from the inside of the governor cover.

H14

Disassembly
Governor RFD (K)



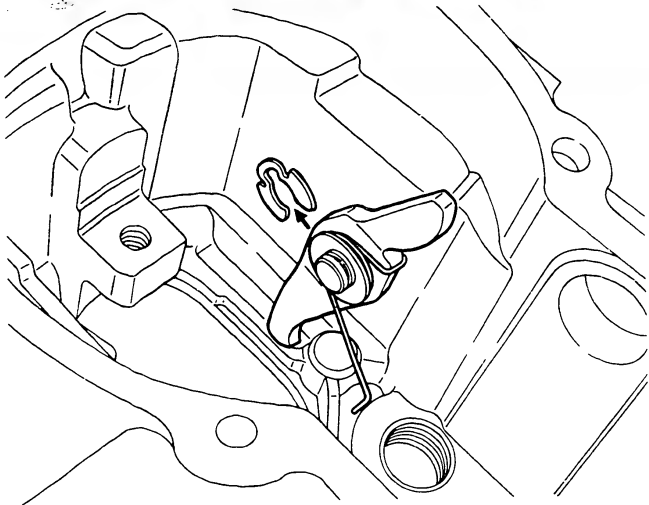

Fig. 106 Removing the torque lever

23. Remove the snapping (167), and then the washer (166), return spring (165) and torque lever (164) from inside the governor cover.

Note: Disassemble the torque lever only when necessary.
Do not remove the plug (163) unless necessary.



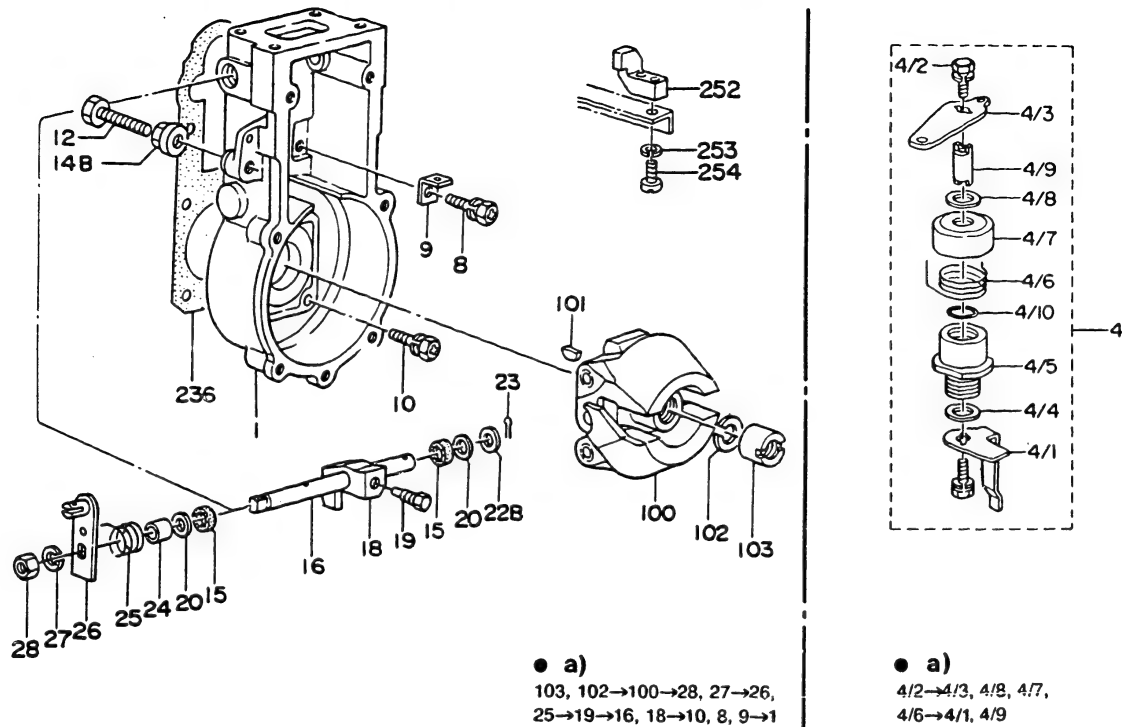
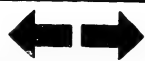

Fig. 107

● a) Disassembly sequence

Governor Housing Disassembly

Figure 107 shows the disassembly sequence for the governor housing. The disassembly procedure is described on the following pages.



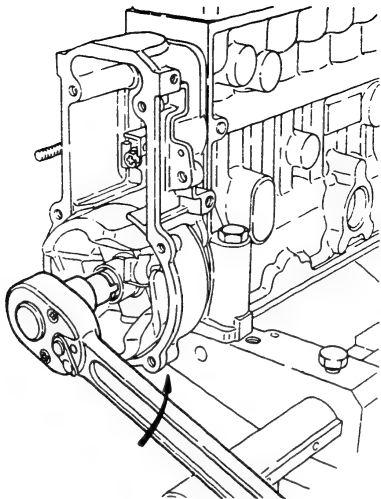

Fig. 108 Removing the roundnut

1. Use the wrench (KDEP 2626) to remove the roundnut (103), while using another wrench (KDEP 2906) on the drive side to prevent camshaft rotation.



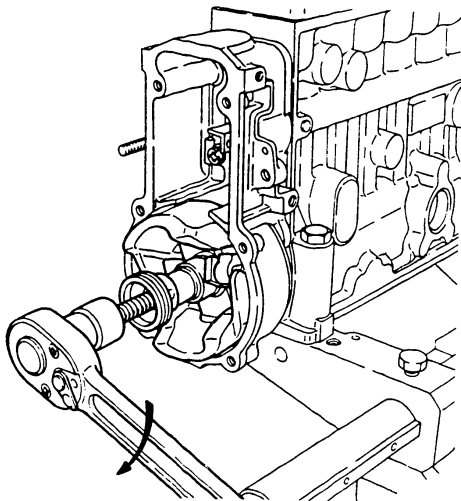

Fig. 109 Removing the flyweight

2. Use the extractor (KDEP 2918) to remove the flyweight while using the wrench (KDEP 2906) to prevent camshaft rotation.



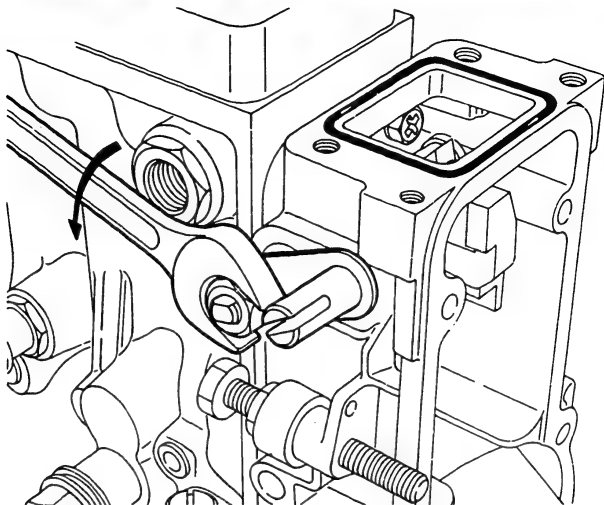
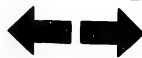

Fig. 110 Removing the stop lever

3. Use a spanner to loosen the nut (28) and then remove the stop lever (26), and the return spring (25).





Abb. 111 Pulling out the shaft

1 = Lever (18)

4. Remove the bolt (19), hold the lever (18) down, and then pull out the shaft (16).

H21

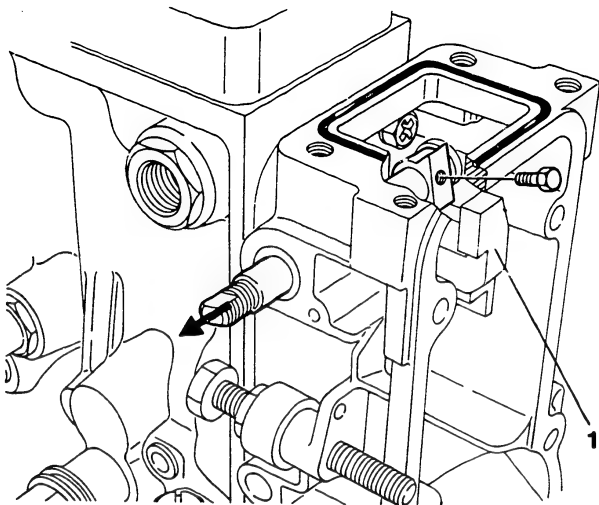
Disassembly
Governor RFD (K)



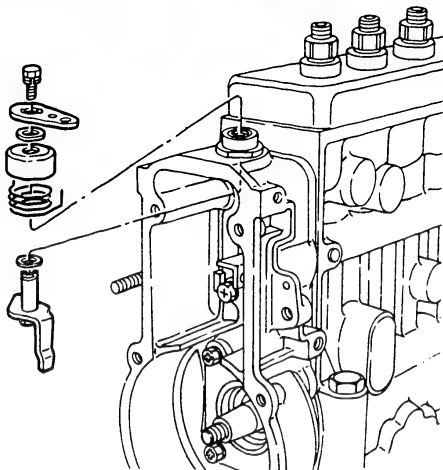

Fig. 112 Removing the stopping device

5. When a stopping device is installed in the top of the governor cover, use the following procedure for disassembly.
 - 1) Use a spanner (SW: 10mm) to loosen the bolt (4/2) and then remove the cover (4/7), return spring (4/6), etc.
 - 2) Pull out the lever shaft (4/9) and the attached lever (4/1) from inside the governor cover.



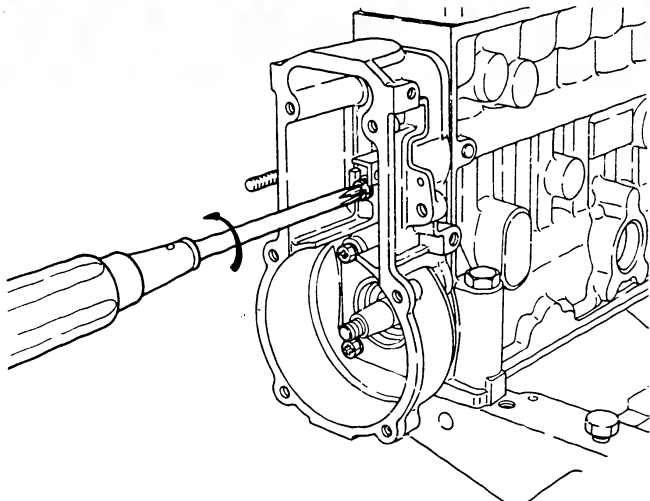

Fig. 113 Removing the eight bolts

6. Use a philips head screwdriver to remove the eight bolts (8, 10).

Note: The spring eye (9) has a common mounting with the bolt (8). Use care to avoid loss when removing.



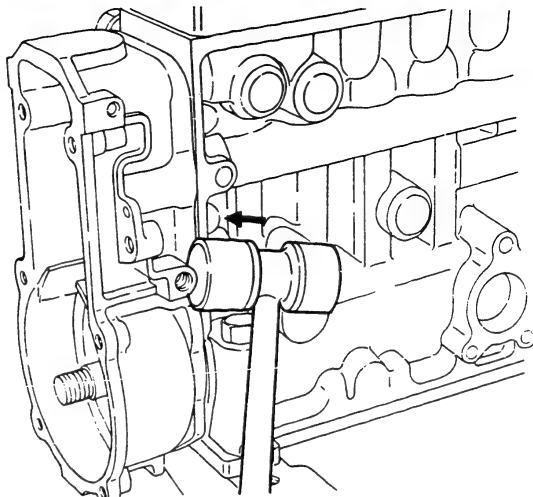

Fig. 114 Removing the governor housing

7. Use a plastic or wooden hammer to remove the governor housing from the pump housing by tapping it lightly.

Note: Make sure that the tappet holders are firmly inserted before performing the above operation.



INSPECTION

After completing the disassembly of the governor assembly and cleaning the parts carefully with diesel oil, inspect all parts for wear or damage and replace with new parts wherever necessary.

Always replace O-rings, gaskets and snaprings with new parts regardless of their condition.

H25

Inspection

Governor RFD (K)



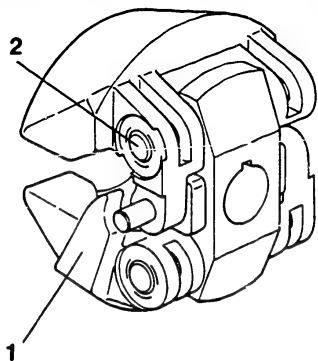
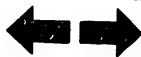

Fig. 115 Flyweight and pin

- 1 = Flyweight
- 2 = Pin

Flyweight assembly

1. Replace the entire flyweight assembly when the gap between the flyweight pin and flyweight is too large.



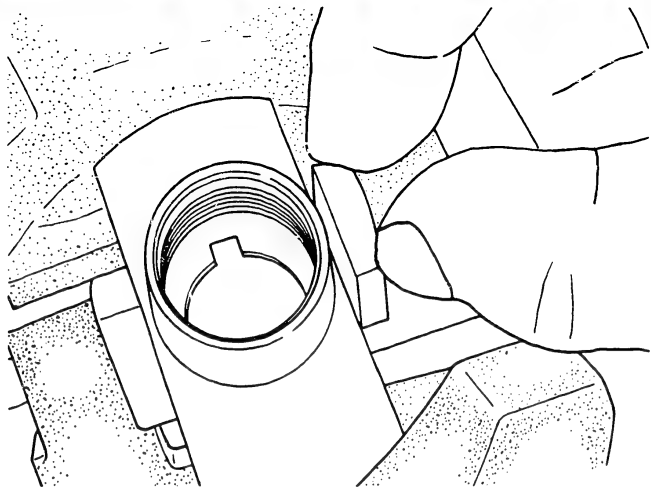

Fig. 116 Check slider for wear

2. Inspect the surface where the slider and sleeve contact. Replace the entire assembly if wear or damage is found. Also replace the assembly if the gap between the slider and pin is too large.

H27

Inspection

Governor RFD (K)

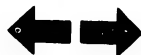

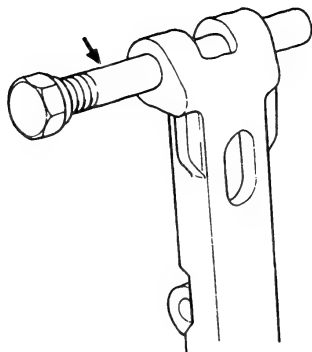

Fig. 117 Check clearance between shaft and tension lever

Tension lever assembly

1. When the tension lever or the tension lever shaft is worn excessively, replace the tension lever or the shaft.



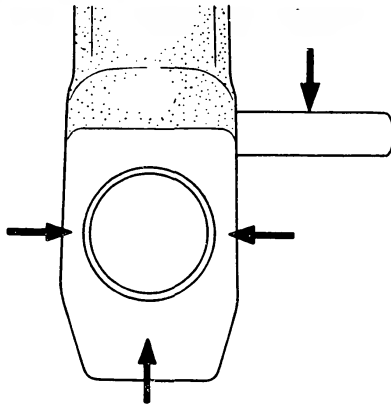

Fig. 118 Inspect each contact section

2. Inspect the areas where the stroke adjusting screw and the shifter contact the tension lever, and where the supporting lever contacts the pin. Replace relevant parts if abnormal wear is found.

J1

Inspection

Governor RFD (K)



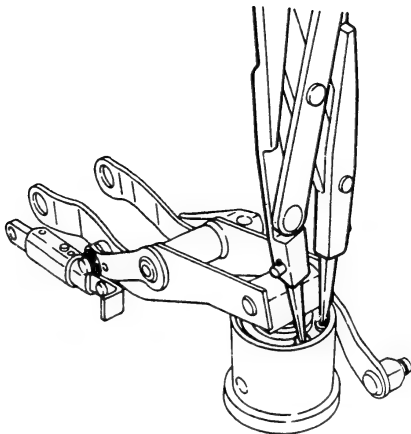

Fig. 119 Removing the snapping

Guide lever assembly

1. If the sleeve mounted on the shifter is worn or damaged, use the following procedure for disassembly.
- 1) Use snapping pliers to remove the snapping connecting the shifter and sleeve.

J2

Inspection

Governor RFD (K)



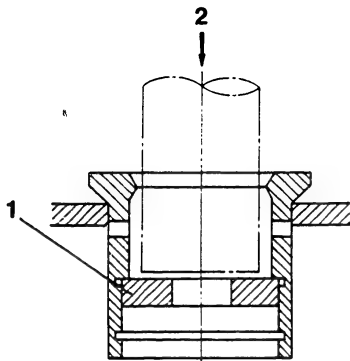

Fig. 120 Removing the bush

1 = Bush

2 = Press

2) Use a press to remove the bush from inside the sleeve.

J3

Inspection

Governor RFD (K)



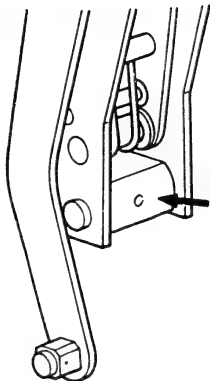

Fig. 121 Shifter inspection

2. Replace the entire guide lever assembly if the end of the shifter (i.e. the part that contacts the tension lever) is worn or the chrome plating has peeled.

J4

Inspection

Governor RFD (K)



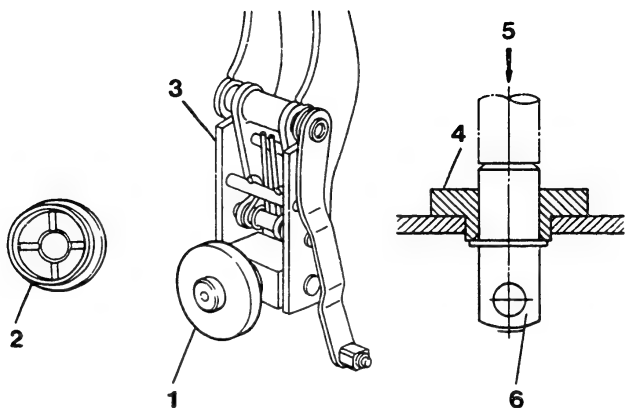

Fig. 122 Shifter and sleeve inspection

- 1 = Plate bearing
- 2 = Sleeve
- 3 = Guide lever
- 4 = Plate bearing
- 5 = Press
- 6 = Shifter

3. Inspect the shifter and sleeve for axial play (axial play is the cause of bearing wear). If play is excessive, replace the bearing. Inspect the connection between the shifter and sleeve for play.
If excessive, replace the entire guide lever assembly.

Note: When replacing the plate bearing, use a press to remove the plate bearing from the shifter.

J5

Inspection

Governor RFD (K)



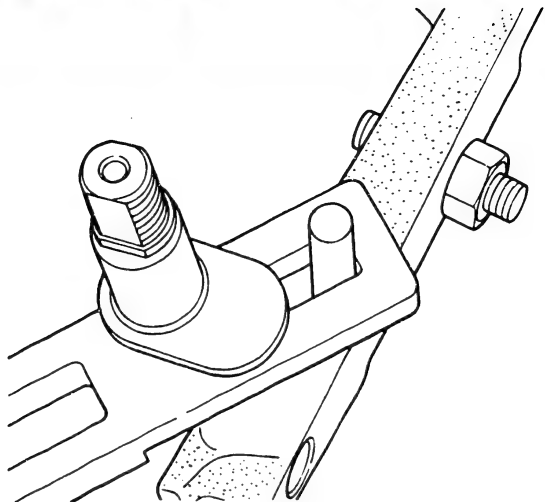

Fig. 123 Tension lever pin inspection

4. Replace the guide lever assembly if play is found between the pin, press-fitted to the tension lever, and the supporting lever.

J6

Inspection

Governor RFD (K)

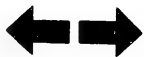

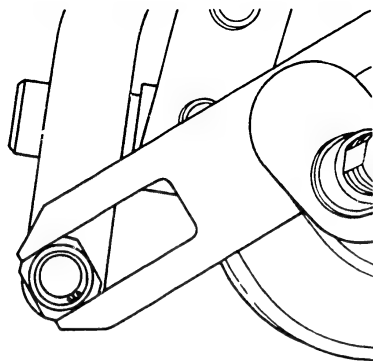

Fig. 124 Inspect the grooved section of the supporting lever

5. Replace the guide lever assembly if play is found between the block at the bottom of the guide lever and the supporting lever.

J7

Inspection

Governor RFD (K)

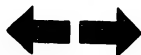

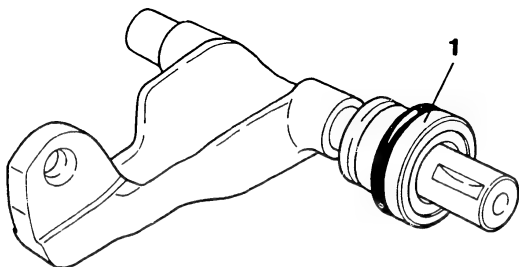

Fig. 125 Speed setting lever inspection

1 = Bush

Speed setting lever

If the gap between the lever shaft and bush is excessive, resulting in oil leakage from the shaft area, replace either the bush or speed setting lever.

J8

Inspection

Governor RFD (K)



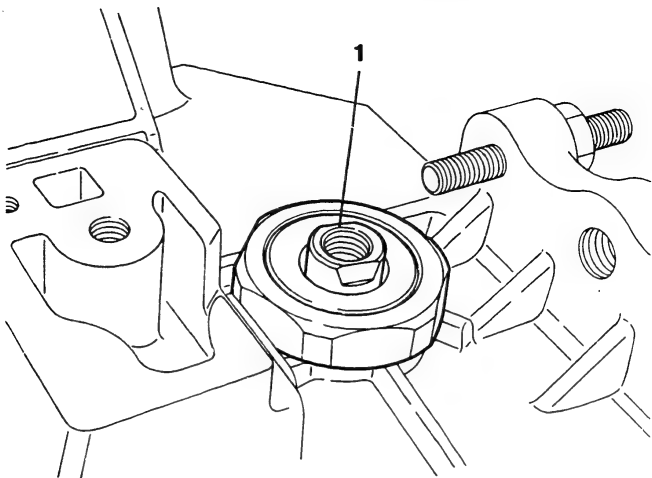

Fig. 126 Load control lever inspection

1 = Lever shaft

Load control lever

If the gap between the lever shaft and bush is excessive, resulting in oil leakage from the shaft area, replace either the bush or lever shaft.

J9

Inspection
Governor RFD (K)



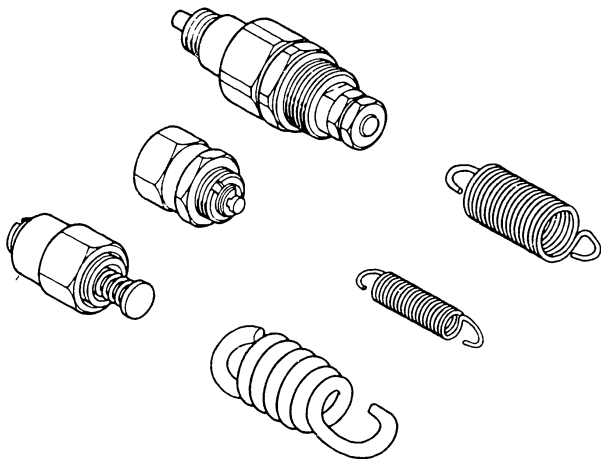

Fig. 127 Springs

Springs

The condition of the springs can be determined while adjusting the governor. However, any spring found during inspection to be bent, weakened, rusted or damaged in any way should be replaced.



REASSEMBLY

Reassembly of the RFD type governor is the reverse of the disassembly procedure.

Points requiring special precautions during reassembly are explained on the following pages.

J11

Reassembly

Governor RFD (K)



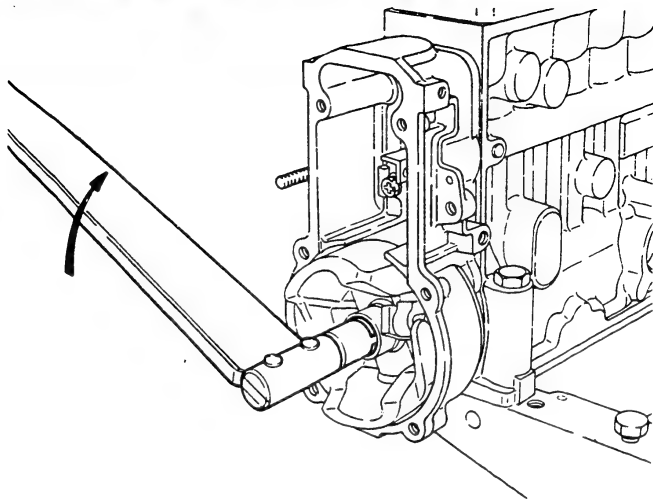

Fig. 128 Tightening the roundnut

Flyweight assembly

After fixing the governor housing (1) to the pump housing, fasten the flyweight (100) to the camshaft using the roundnut (103).

Standard tightening torque: 5~6kg·m

Note: When installing the flyweight, attach the wrench (KDEP 2906) to the drive side to prevent camshaft rotation.



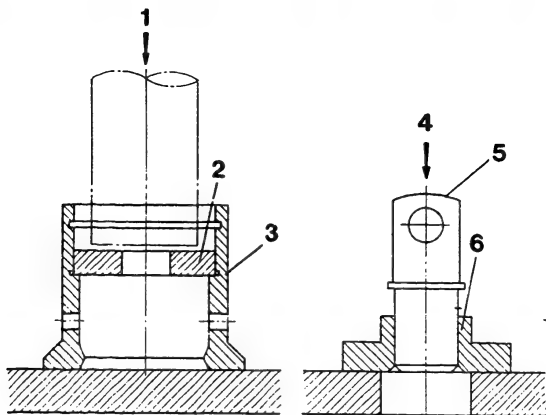

Fig. 129 Press-fitting the bush

- 1 = Press
- 2 = Bush
- 3 = Sleeve
- 4 = Press
- 5 = Shifter
- 6 = Plate bearing

Shifter and sleeve

1. Use a press to correctly press-fit the shifter into the plate bearing; then press-fit the bush into the sleeve.



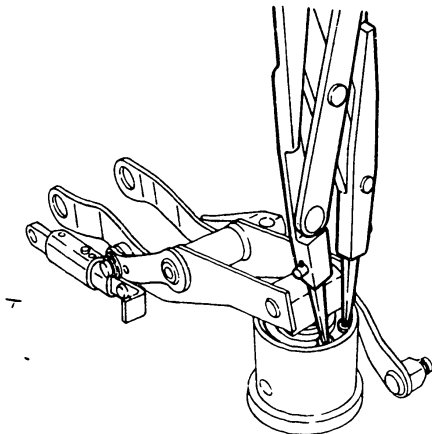

Fig. 130 Sleeve inspection

2. After mounting the shifter on the guide lever, connect the plate bearing, with the sleeve attached, to the shifter using a snapping. When assembly is completed, rotate the sleeve to make sure it rotates smoothly.



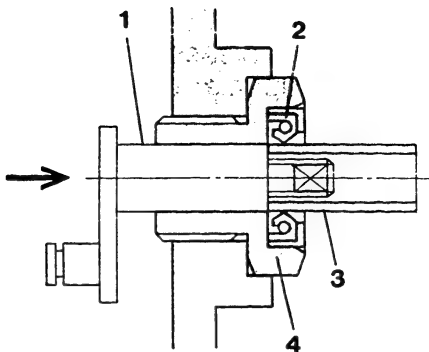

Fig. 131 Mounting the eccentric shaft

- 1 = Lever shaft
- 2 = Oil seal
- 3 = Guide
- 4 = Bush

Internal governor parts

1. Use a guide to prevent the oil seal from folding when installing the lever (205) from inside the governor housing, and to facilitate installation.
2. After installing the lever shaft (205), install the load control lever.



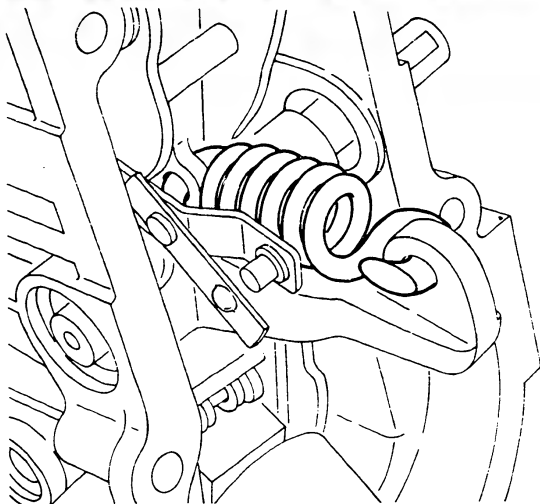

Fig. 132 Attaching the governor spring

3. Attach the governor spring (130) to the tension lever (181) and install the speed setting lever.

Note: The chamfered part of the governor spring's hook should face the link (174) and be attached to the speed setting lever (150).



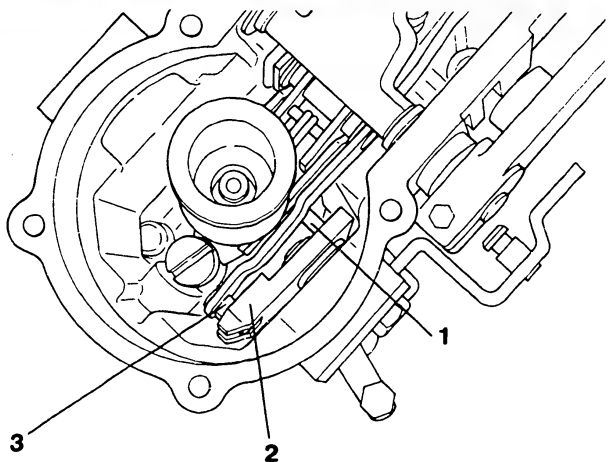

Fig. 133 Check to see that pin and block are properly assembled

- 1 = Pin
- 2 = Supporting lever
- 3 = Block

4. Insert the block at the bottom of the floating lever into the groove in the bottom of the supporting lever, and insert the pin press-fitted into the tension lever into the long slot in the top of the supporting lever.



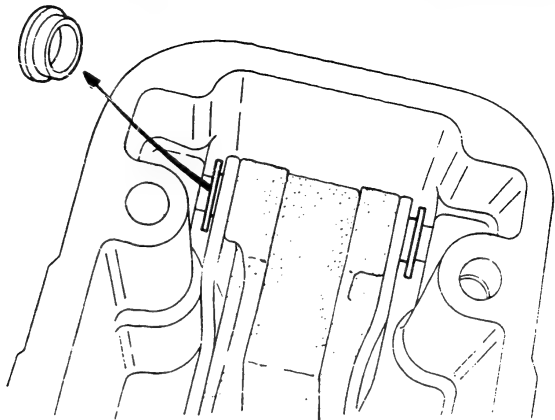

Fig. 134 Inserting the tension lever shaft

5. Insert the tension lever shaft (182) into the holes in the tops of the guide lever, tension lever and supporting lever from outside the governor cover.

Note: Be sure to install the bushes (183) on both sides of the guide lever.



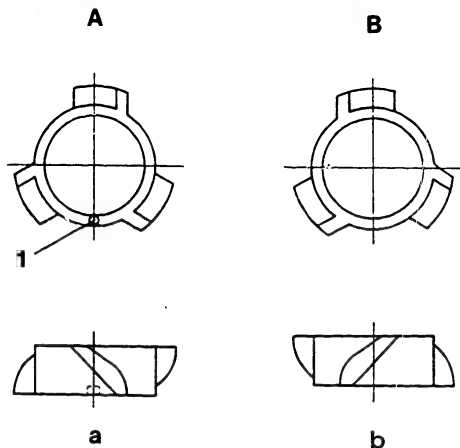

Fig. 135 Impellers

A = For clockwise rotation
(with distinguishing
groove)

B = For counterclockwise
rotation

1 = Groove

a = Governor side

b = Governor side

- After mounting the governor housing, attach the impeller to the camshaft with the flat side of the blades facing the governor.

The impeller (235) can only be installed in one direction. Use care to avoid error.



ADJUSTMENT

An abbreviated version of the RFD (K) Type mechanical governor's adjustment procedure is shown in the following.

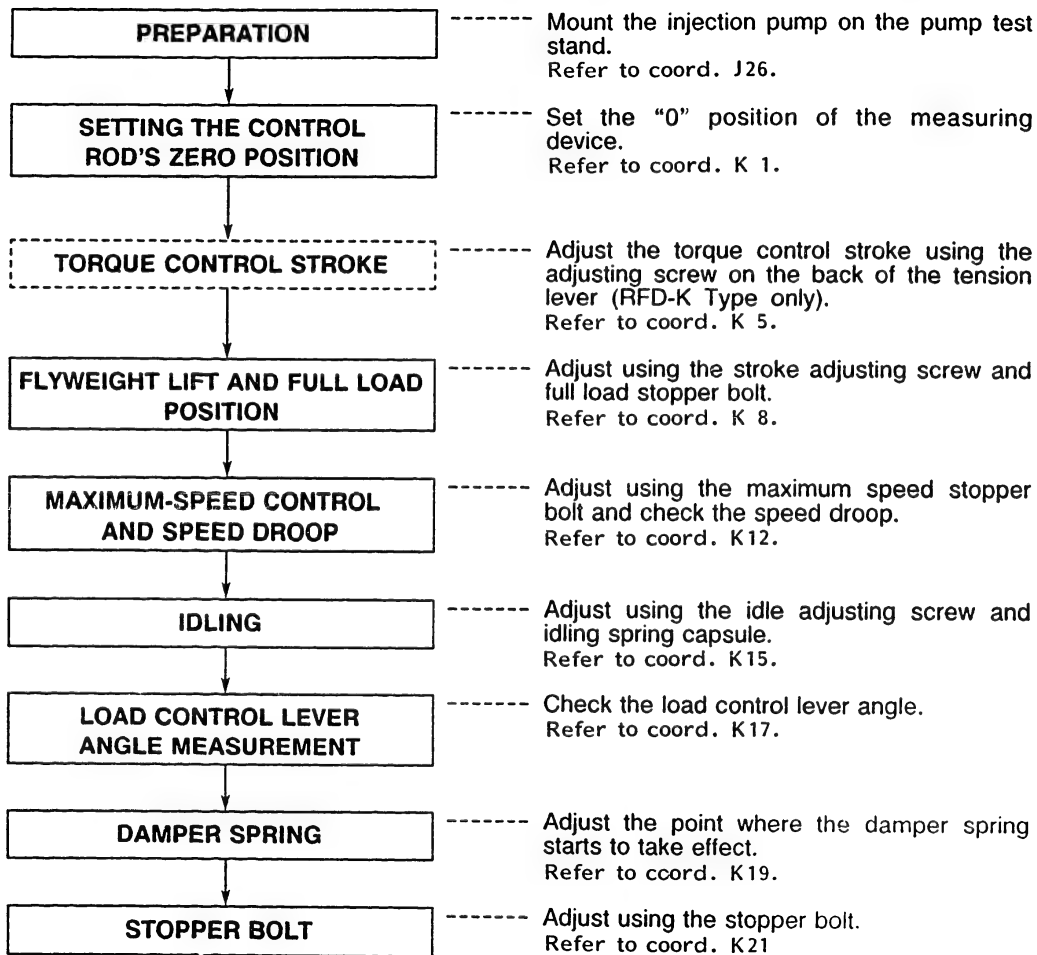

J20

Adjustment
Governor RFD (K)



J21

Adjustment
Governor RFD (K)



Adjustment (cont' d)

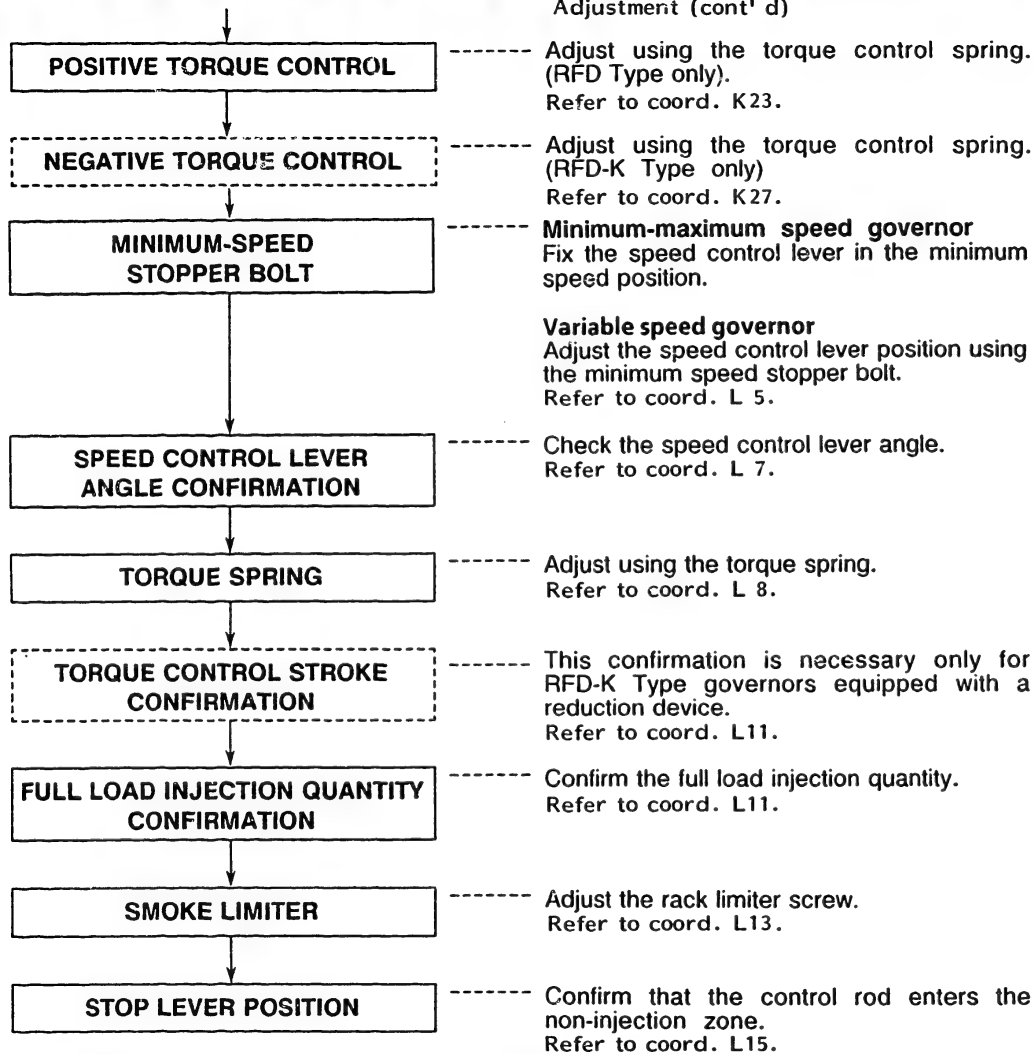

J22

Adjustment
Governor RFD (K)



J23

Adjustment
Governor RFD (K)



Adjustment (cont' d)

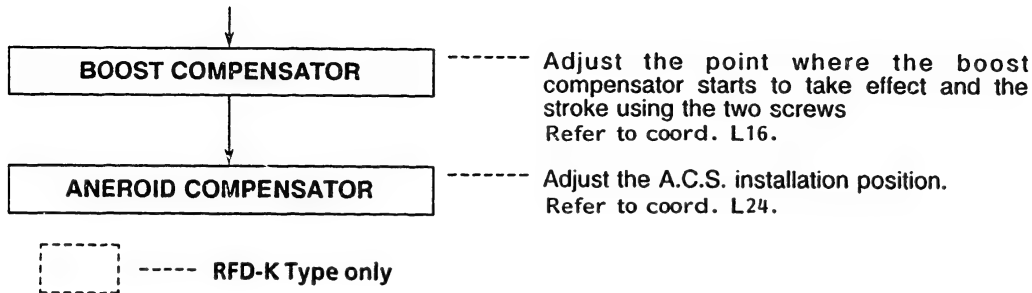

Note: The adjustment sequence may vary, depending on the governor specifications. Typical RFD (K) type governor performance graphs and adjustment procedures are shown on coord. L27.

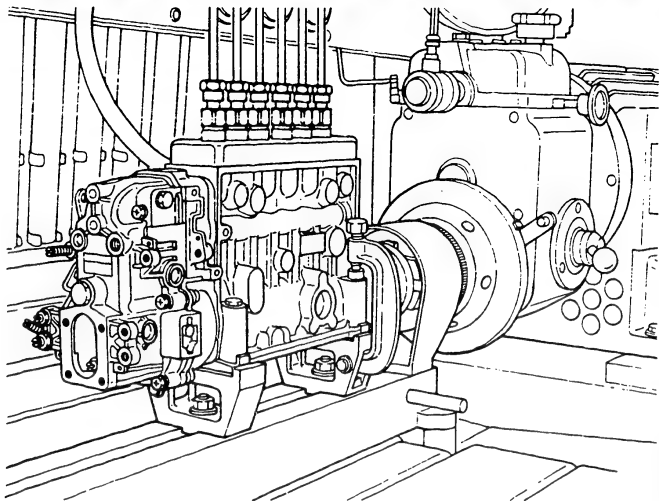

Fig. 136 Mounting the injection pump

Preparation

1. Use a stand to mount the pump being tested on the pump test stand.
2. Connect the fuel pipe and injection pipes.
3. Remove the damper spring (220), closing cover (80), torque control springs (340, 331) and idling spring (140). Also loosen the adjusting screw (181/3).
4. If a boost compensator is installed, remove it from the governor.



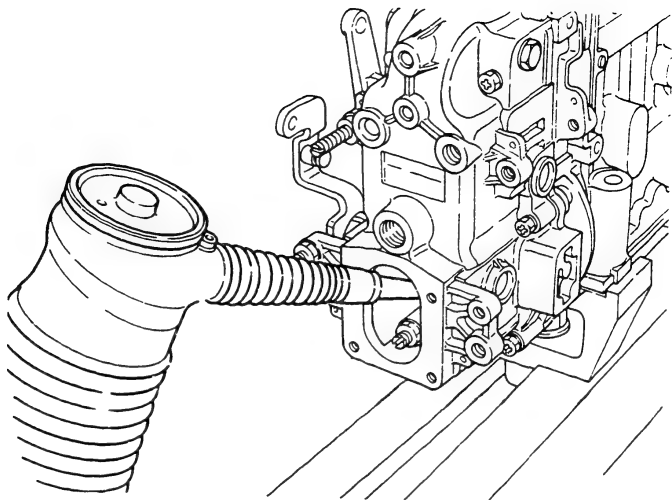

Fig. 137 Supplying oil

5. Fill the pump cam chamber and governor chamber with lubricating oil.

- **Cam chamber**
PE-A Type : 20cc/cyl.
PE-P Type : 40cc/cyl.
- **Governor chamber**
PE-A Type : 200cc
PE-P Type : 240cc



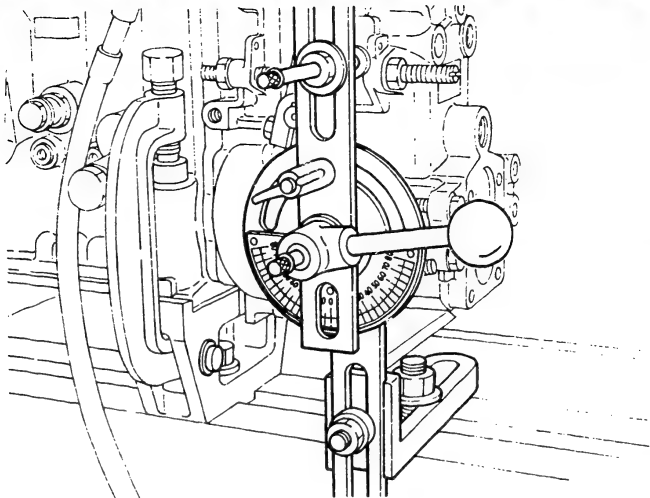

Fig. 138 Mounting the measuring device

6. Attach the adjusting device for fixing the control lever to the load control lever.



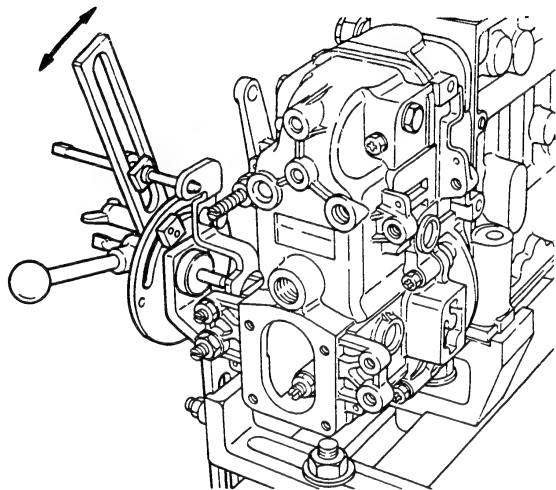

Fig. 139 Checking control rod movement

7. With the pump stopped, operate the load control lever and check that the control rod moves smoothly in the fuel-increase and decrease directions.

Setting the Control Rod's Zero Position

1. Remove the rack limiter (or rack cap) mounted on the pump's drive side and then mount the measuring device used for setting the control rod position.

Note: If a boost compensator is installed on the pump's drive side, remove it and then mount the measuring device.

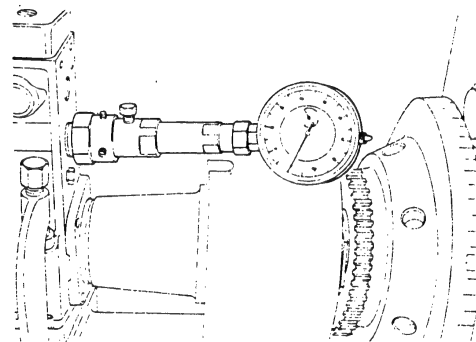
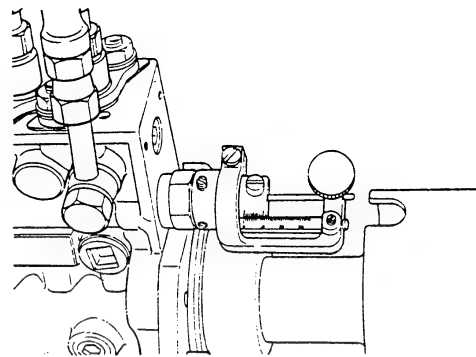
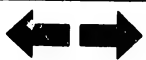

Fig. 140 Mounting the measuring device

K1

Adjustment
Governor RFD (K)



K2

Adjustment
Governor RFD (K)

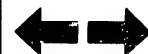

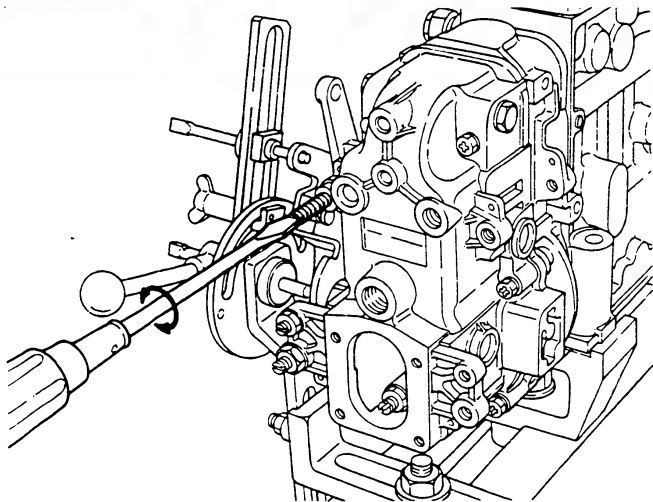

Fig. 141 Temporarily fixing the speed control lever

2. Fix the load control lever in the idling position.
3. Drive the pump at 500rpm~600rpm and temporarily fix the speed control lever so that governor control starts within this speed range.

K3

Adjustment

Governor RFD (K)



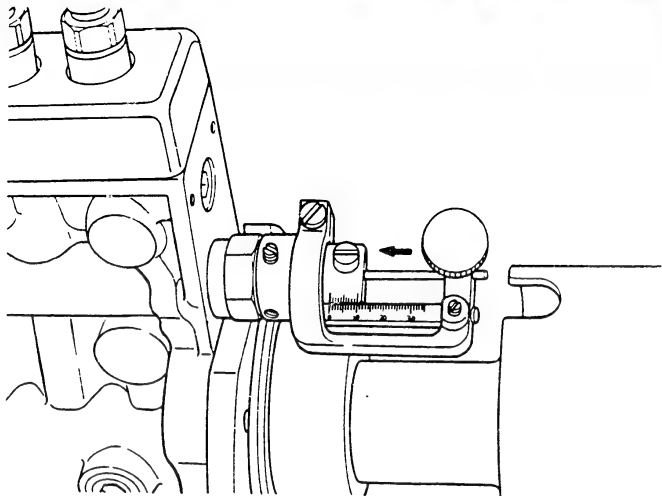

Fig. 142 Setting the "zero" position

4. Increase pump speed so that the control rod travels to the non-injection position. Push the end of the measuring device mounted on the end of the control rod fully to the governor side and set the measuring device at "0".

Notes:

- With PE-A Type pumps, push the pinion fully to the governor side and then set the measuring device at "0".
- Do not set the control rack's "J" position by operating the control lever when the pump is not being driven. This can damage the link connection.

K4

Adjustment

Governor RFD (K)



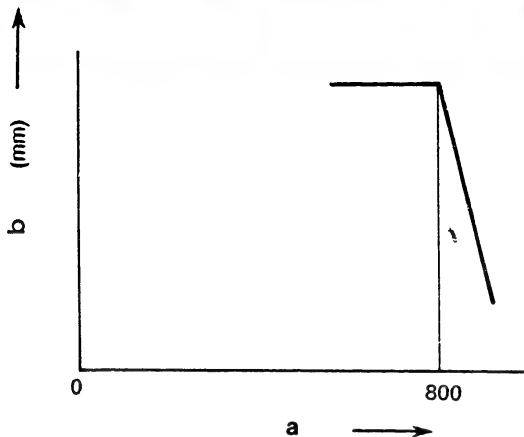

Fig. 143

a = Pump speed (rpm)
 b = Control rack position

Torque Control Stroke (RFD-K Type only)

1. Temporarily fix the load control lever in the full load position.
2. Temporarily set the speed control lever so that governor control starts at a pump speed of approximately 800rpm (refer to Fig. 143).

Note: Check the calibration data for the pump speed at which governor control starts before setting the speed control lever.

K5

Adjustment
 Governor RFD (K)



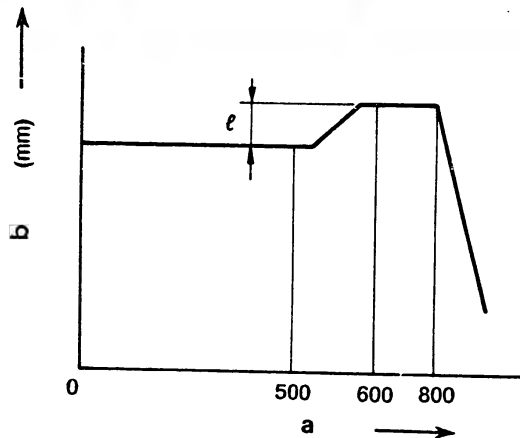

Fig. 144

a = Pump speed (rpm)
 b = Control rack position

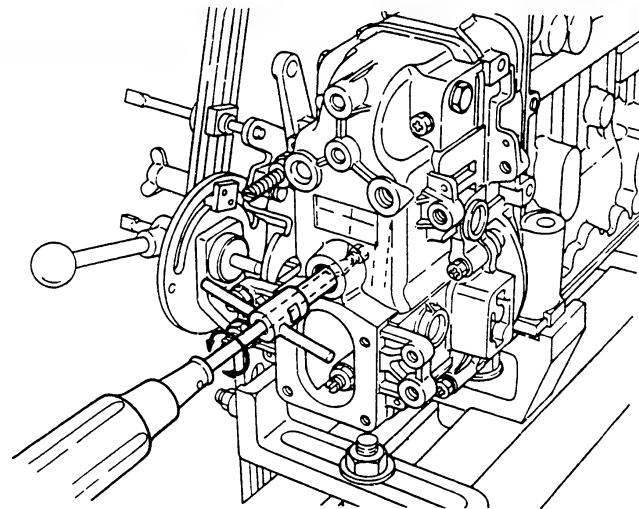
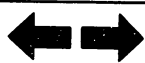

Fig. 145 Torque control stroke adjustment

3. Increase and decrease the pump speed in the 500 - 600 rpm range while using the wrench (KDEP 2605) to adjust the adjusting screw (181/3) so that the stroke of the control rod is only the specified amount "e" (refer to Figs. 144 and 145).

K6

Adjustment
 Governor RFD (K)



K7

Adjustment
 Governor RFD (K)



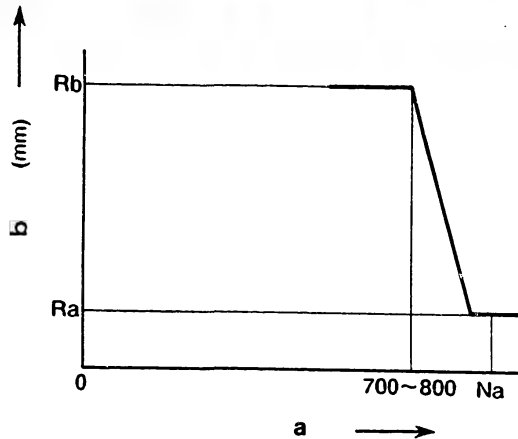

Fig. 146

a = Pump speed (rpm)
 b = Control rack position

Flyweight Lift and Full Load Position

Total flyweight lift includes the lift necessary for high-speed control and the lift necessary for idling.

1. Temporarily fix the load control lever in the full load position (control rod position "Rb").
2. Temporarily set the speed control lever so that governor control starts at a pump speed of approx. 700 - 800 rpm.
3. Increase the pump speed to "Na rpm" and adjust using the full load stopper bolt (48) so that the control rod position is "Ra" (refer to Figs. 146 and 147).

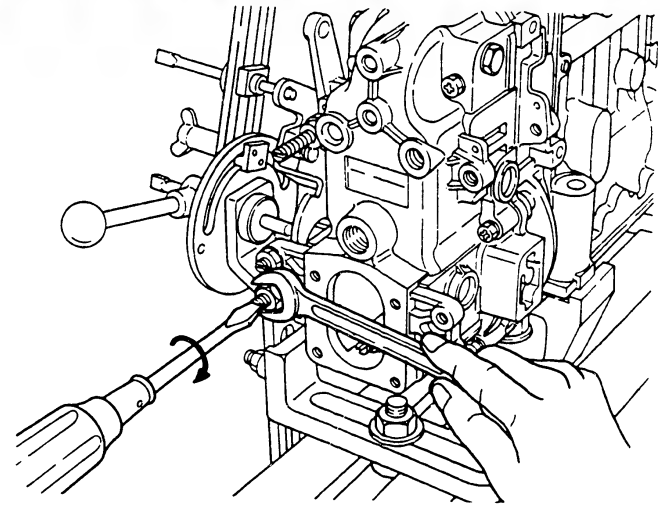

Fig. 147 Adjustment of control rod position "Ra"

K8

Adjustment
 Governor RFD (K)



K9

Adjustment
 Governor RFD (K)

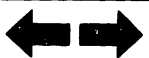

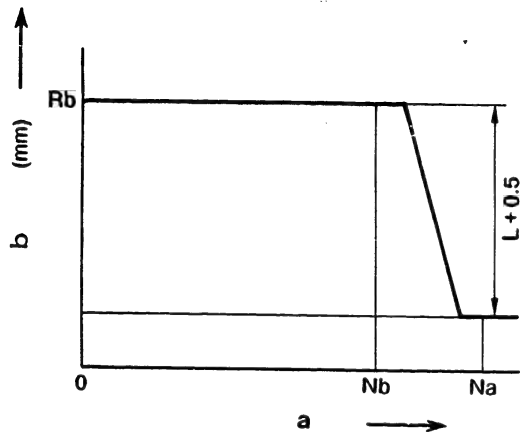

Fig. 148

a = Pump speed (rpm)
 b = Control rack position

- Next, lower the pump speed to "Nb rpm" and adjust the high-speed lift to "L" using the stroke adjusting screw (38) (refer to Figs. 148 and 149).

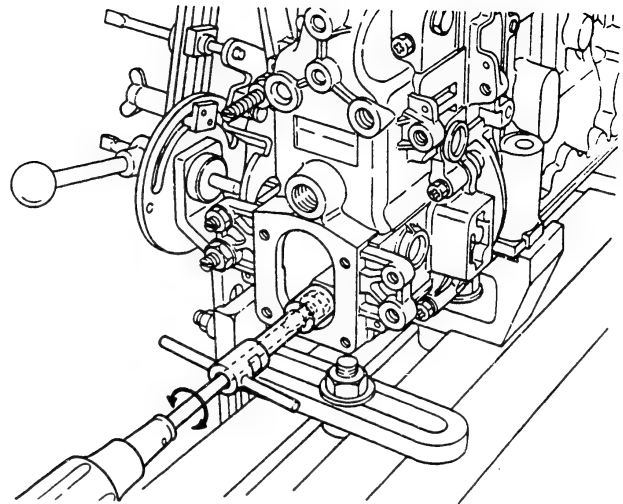

Fig. 149 Adjustment of flyweight lift for high speed control "L"

K10	Adjustment	← →
	Governor-RFD (K)	

K11	Adjustment	← →
	Governor RFD (K)	

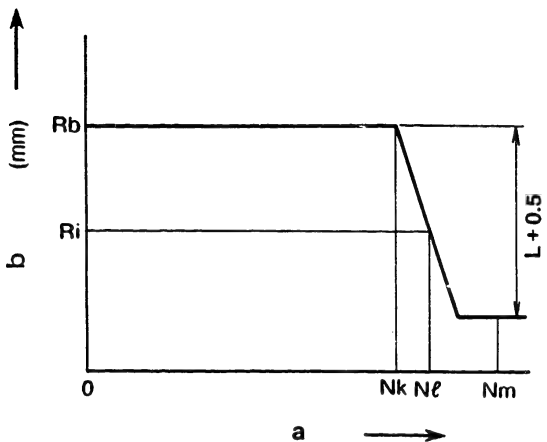

Fig. 150

a = Pump speed (rpm)
b = Control rack position

Maximum-Speed Control and Speed Droop

1. Set the load control lever to the full position. Temporarily fix the speed control lever in the maximum speed position.
2. Slowly increase the pump speed, adjust the minimum speed stopper bolt (53) so that the control rod starts moving in the fuel-decrease direction at "Nk rpm" and then fix the locknut (refer to Figs. 150 and 151).
3. Further increase the pump speed and check that the pump speed is "Nl rpm" or less when the control rod is at the "Ri" position.
Also increase the pump speed and confirm the flyweight lift (L) for high speed control (refer to Fig. 150).

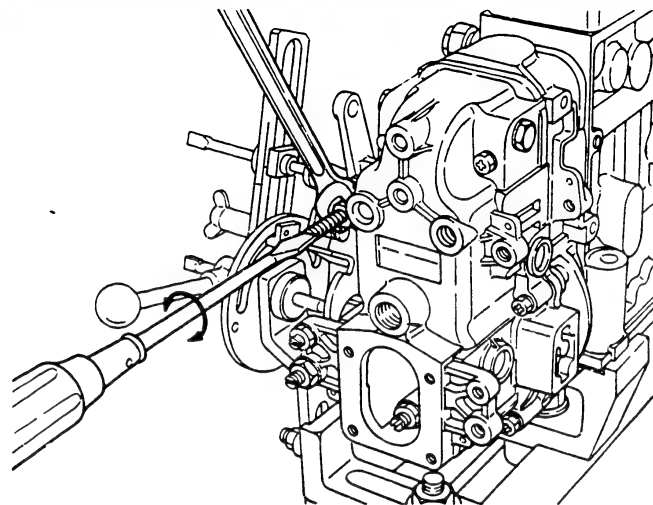
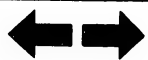

Fig. 151

K12

Adjustment
Governor RFD (K)



K13

Adjustment
Governor RFD (K)

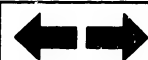

Note:

- **When the high-speed droop confirmation point is at the point where the damper spring is operating, adjust the idling and damper springs and then make the above adjustments and confirmations.**
- **Replace the governor spring if the specified values cannot be obtained.**
- 4. **Further increase the pump speed and confirm that the control rod is in the non-injection zone (or 3cc/1000st or less) at "Nm rpm."**

K14

Adjustment

Governor RFD (K)



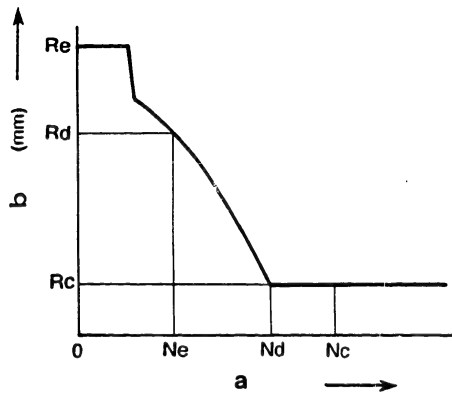

Fig. 152

a = Pump speed (rpm)
b = Control rack position

Idling

1. Drive the pump at "Nc rpm" (Nd + 100 rpm).
2. Adjust the control rod position to "Rc" using the idle adjusting screw (50) (refer to Figs. 152 and 153).
3. Decrease the pump speed to "Ne rpm" and adjust the idling spring capsule (140) using the wrench (KDEP 2648) so that the control rod position is "Rd" (refer to Figs. 152 and 154).
4. Confirm that the control rod position is "Re" or more when the pump speed is 0 rpm and that the control rod position is "Rc" when the pump speed is increased to "Nd rpm" (refer to Fig. 152).

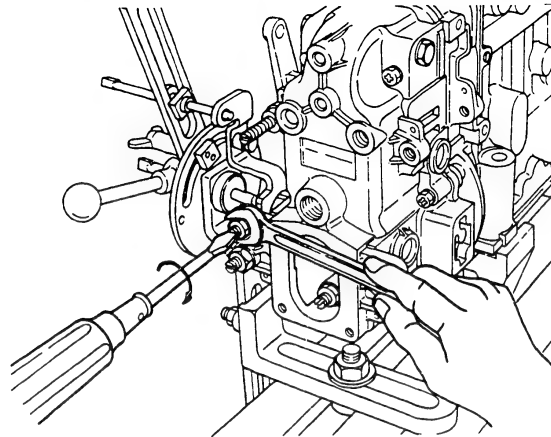

Fig. 153 Adjustment of control rod position "Rc"

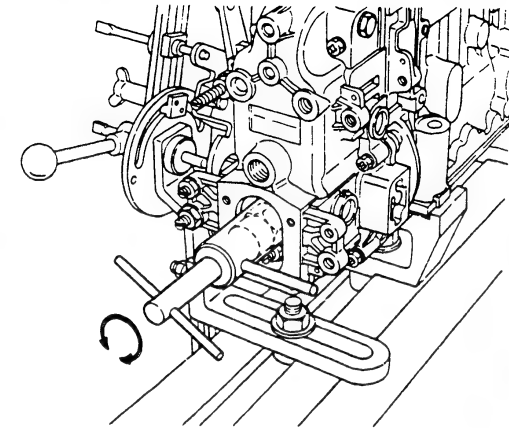
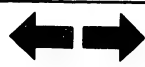

Fig. 154

K15

Adjustment
Governor RFD (K)



K16

Adjustment
Governor RFD (K)

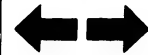

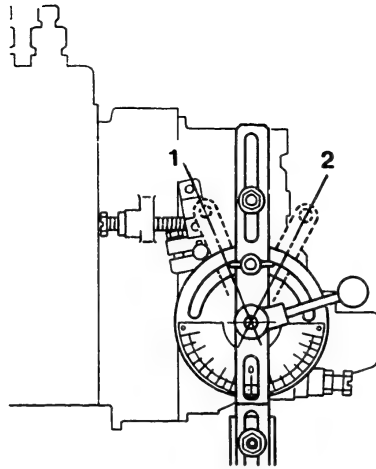

Fig. 155 Load control lever angle measurement

- 1 = Full load position
- 2 = Idling position

Load Control Lever Angle Measurement

Confirm that the lever angles are as specified when the load control lever is at the idling position and the full load position. If not as specified, replace the shim located between the shifter and sleeve.

Note: When the shim is replaced, the maximum speed control and idling adjustments must be repeated.

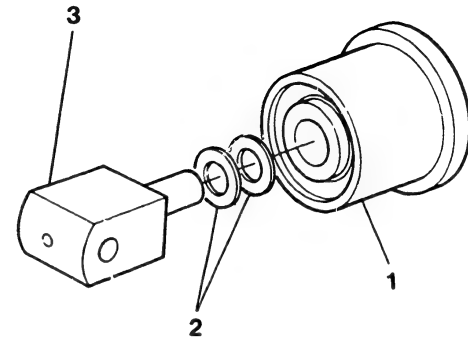

Fig. 156

- 1 = Sleeve
- 2 = Shim
- 3 = Shifter

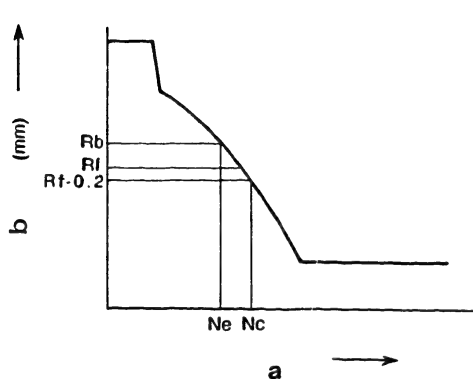

Fig. 157

a = Pump speed (rpm)
b = Control rack position

Damper Spring

1. Hold the load control lever at the idling position.
2. Slowly increase the pump speed from idling speed "Ne rpm", and maintain the pump speed of "Nc rpm" where the control rod position is "Rf-0.2 mm".
3. Screw in the damper spring (220) so that the rod position is "Rf"-0.1 mm and fix it with the locknut (refer to Figs. 158 and 159).

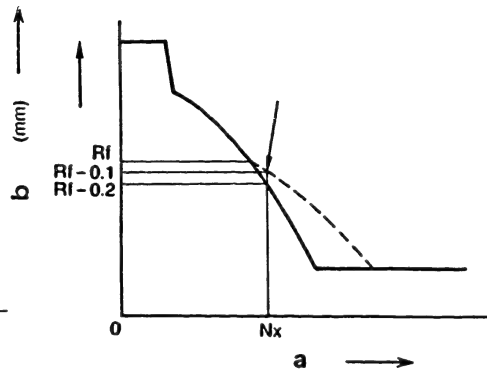

Fig. 158 Set position of damper spring

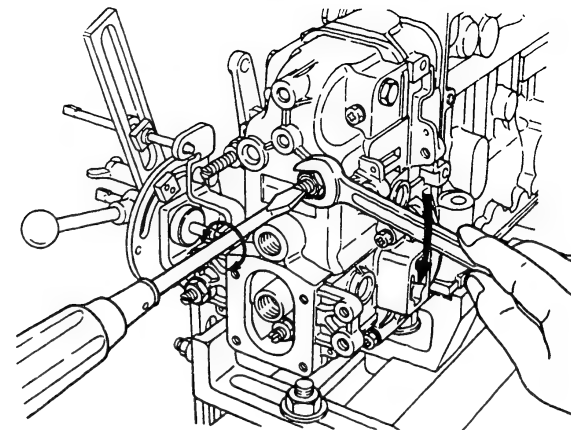

Fig. 159 Setting the damper spring

a = Pump speed (rpm)
b = Control rack position

K19

Adjustment
Governor RFD (K)



K20

Adjustment
Governor RFD (K)

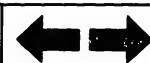

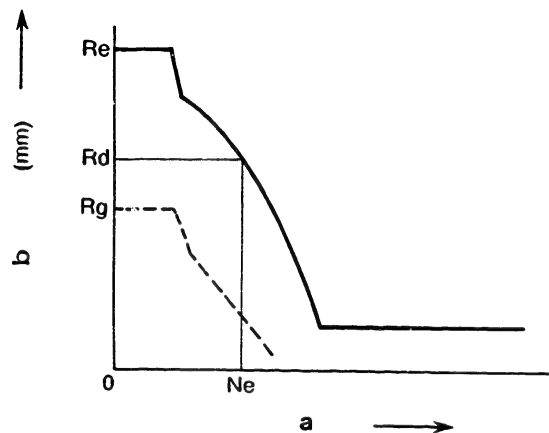

Fig. 160

a = Pump speed (rpm)
b = Control rack position

Stopper Bolt

If idling performance is included in calibration data, as represented by the dotted line in Figure 160, adjust the setting of the idle adjusting screw (50).

1. After adjusting the damper spring, the control rod position should be "Re" when the pump is stopped.
2. Under the above conditions, loosen the idle adjusting screw (50) and adjust it so that the control rod position is "Rg" (refer to Figs. 160 and 161).

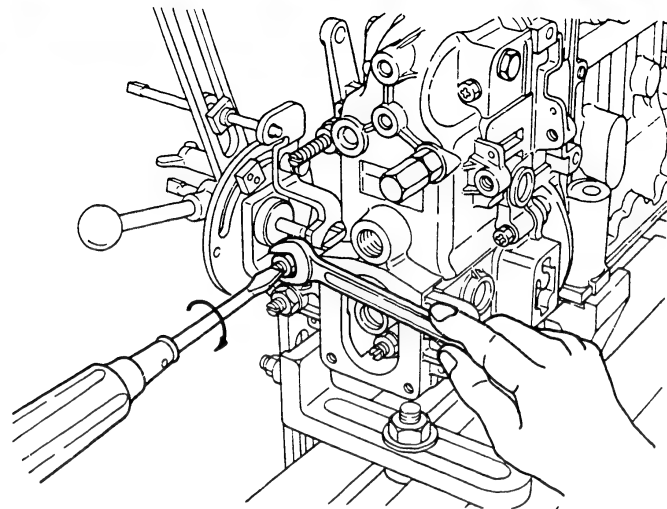

Fig. 161

K21

Adjustment
Governor RFD (K)



K22

Adjustment
Governor RFD (K)



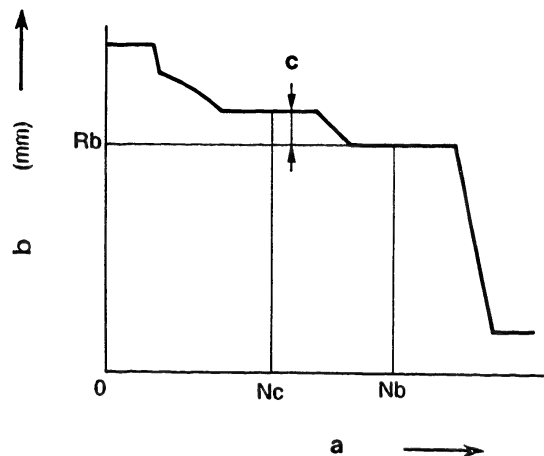

Fig. 162

- a = Pump speed (rpm)
 b = Control rack position
 c = Torque control stroke

Positive Torque Control (when installed)

1. Drive the pump at "Nc rpm" and hold the load control lever in the full load position.
2. Next, adjust the torque control spring capsule (331) using the wrench (KDEP 2648) so that the torque control stroke is the specified value.
 After adjustment, fix it securely with a locknut (refer to Figs. 162 and 163).

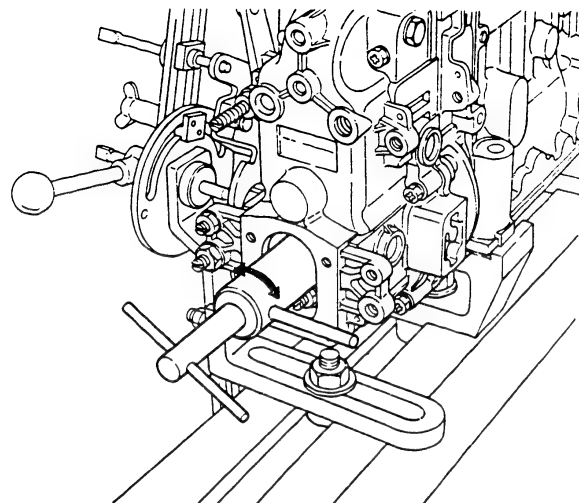
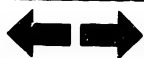

Fig. 163 Torque control spring adjustment

K23

Adjustment
 Governor RFD (K)



K24

Adjustment
 Governor RFD (K)



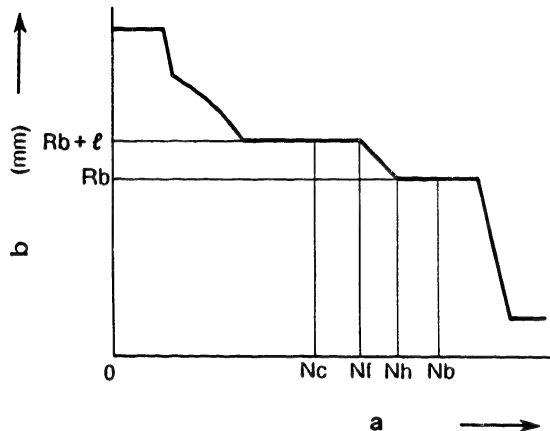

Fig. 164

a = Pump speed (rpm)
 b = Control rack position

3. Slowly increase the pump speed from "Nc rpm" and adjust the screw so that the torque control spring starts to take effect at "Nf rpm" (refer to Figs. 164 and 165).

Note: When shims are used, adjust by varying the shim thickness.

4. Increase the pump speed and confirm that the torque control spring stops taking effect at "Nh rpm."

5. Increase and decrease the pump speed between "Nc rpm" and "Nb rpm" and confirm that the torque control stroke is the specified value.

Note: ● If the torque control stroke is not the specified value, readjust using the spring capsule screw.
 ● If the torque control spring does not stop taking effect at the specified speed, replace the spring capsule.

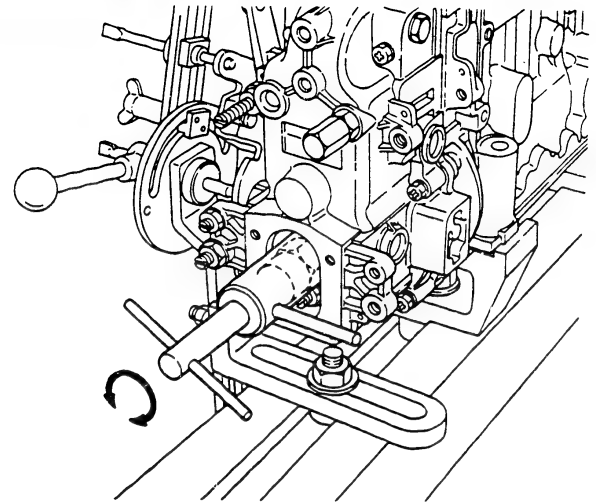

Fig. 165

K25	Adjustment	↔
	Governor RFD (K)	

K26	Adjustment	↔
	Governor RFD (K)	

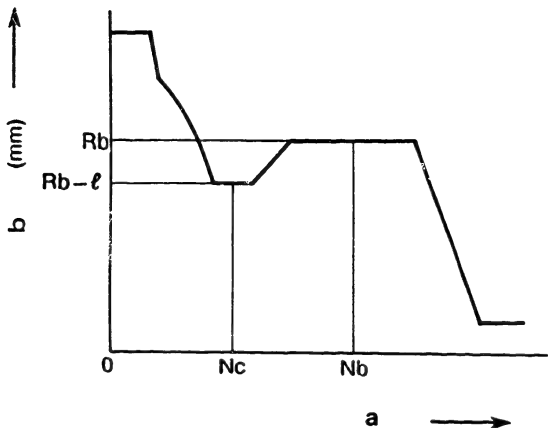

Fig. 166

a = Pump speed (rpm)
 b = Control rack position

Negative Torque Control (RFD-K Type only)

1. Fix the load control lever in the full load position.
2. Confirm that the control rod is in the "Rb-l" position at a pump speed of "Nc rpm."
3. Next, confirm that the control rod is at the "Rb" position at a pump speed of "Nb rpm."



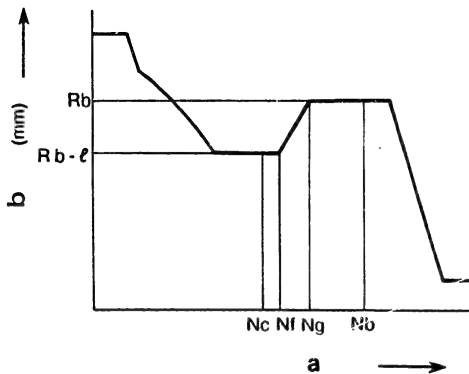

Fig. 167

a = Pump speed (rpm)
b = Control rack position

4. Drive the pump at "Nc rpm", screw the torque control spring (331) into the guide screw (141) and set the guide screw (341) before control rod position "Rb - l" changes.
5. Increase the pump speed from "Nc rpm" and adjust using the screw so that the torque control spring starts taking effect at "Nf rpm".
6. Increase the pump speed and confirm that the torque control spring stops taking effect at "Ng rpm".
7. Increase and decrease the pump speed between "Nc rpm" and "Nb rpm" and confirm that the negative torque control stroke is as specified.

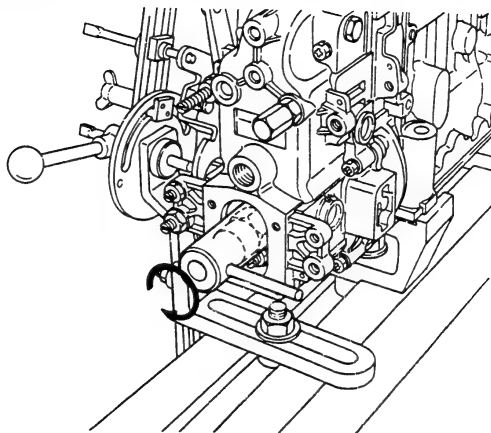

Fig. 168 Torque control stroke adjustment

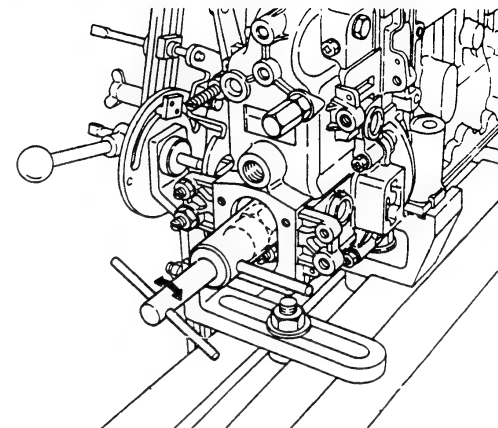

Fig. 169 Torque control spring adjustment

L1

Adjustment
Governor FFD (K)



L2

Adjustment
Governor RFD (K)



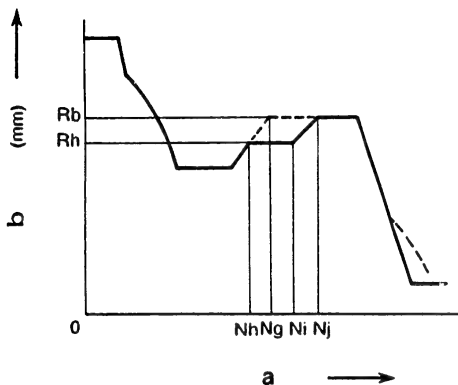

Fig. 170

a = Pump speed (rpm)
b = Control rack position

8. If the No. 2 torque spring is installed, screw it (340) into the guide screw (341).
9. Adjust the No. 2 torque control spring capsule so that the control rod is at the "Rh" position at a pump speed of "Ng rpm" and then fix it with the locknut (332) (refer to Figs. 170 and 171).
10. Increase the pump speed and adjust the screw so that the torque control spring starts taking effect at "Ni rpm" (refer to Fig. 172).
11. Confirm the point where the No. 1 torque control spring stops taking effect ("Nh" rpm) and the points where the No. 2 torque control spring starts ("Ni" rpm) and stops ("Nj" rpm) taking effect (refer to Fig. 170).

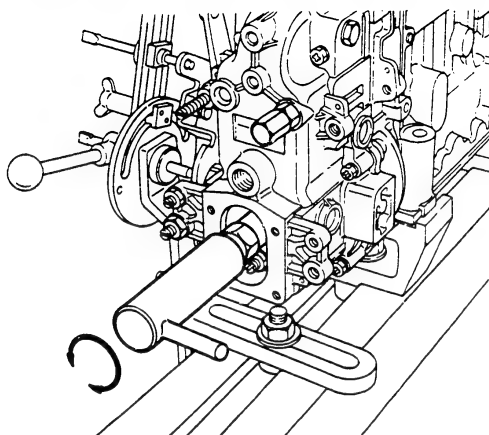

Fig. 171 No. 2 torque control stroke adjustment

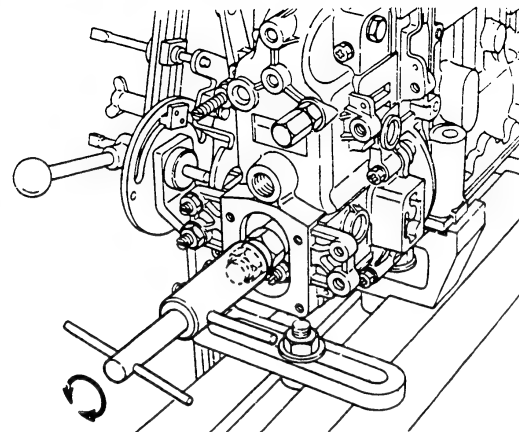

Fig. 172 No. 2 torque control spring adjustment

L3

Adjustment
Governor RFD (K)



L4

Adjustment
Governor RFD (K)



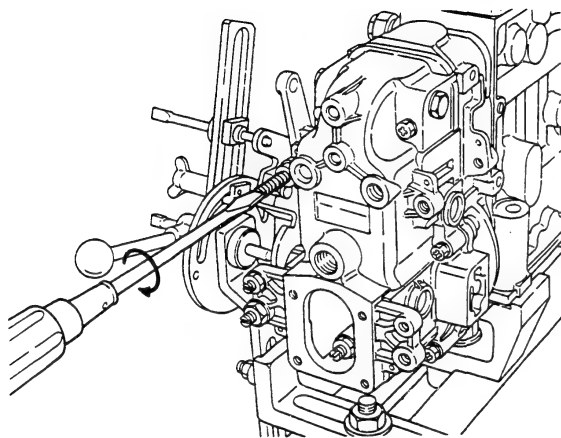

Fig. 173 Setting the speed control lever

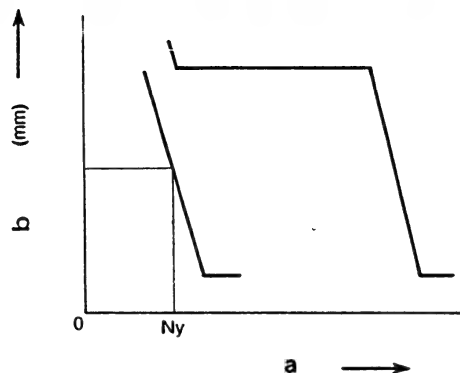

Fig. 174

a = Pump speed (rpm)
b = Control rack position

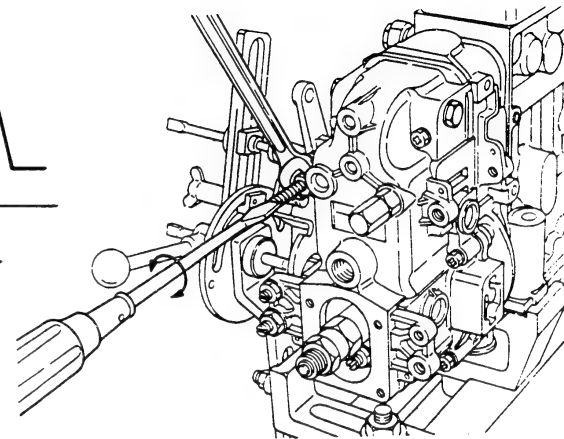

Fig. 175 Adjustment of control rod position "Rb"

Minimum-Speed Stopper Bolt

- Minimum-maximum speed governor

1. Move the speed control lever until it contacts the maximum speed stopper bolt, and then screw the minimum speed stopper bolt (53) in until it contacts the speed control lever.

- Variable-speed governor

1. Fix the load control lever in the full load position.
2. Return the speed control lever in the fuel-decrease direction and drive the pump at "Ny rpm", slightly faster than idling speed.
3. Next, adjust the minimum-speed stopper bolt (53) so that the control lever is at the "Rb/Ny" position and then fix it with the locknut (14).

L5

Adjustment
Governor RFD (K)

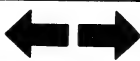

L6

Adjustment
Governor RFD (K)

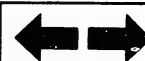

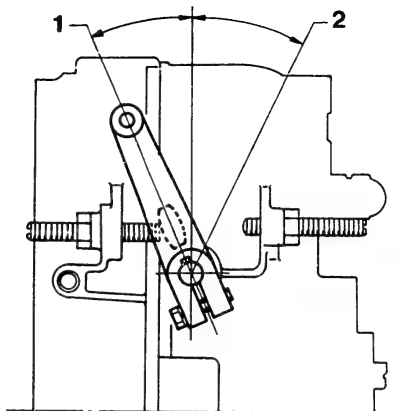

Fig. 176

1 = Maximum speed

2 = Minimum speed

Speed Control Lever Angle Confirmation

1. Confirm that the angle of the speed control lever is the specified value at the maximum-speed position.
2. Confirm that the angle of the speed control lever is the specified value at the minimum-speed position.
3. If the angle is not as specified, replace the governor spring.

L7

Adjustment
Governor RFD (K)



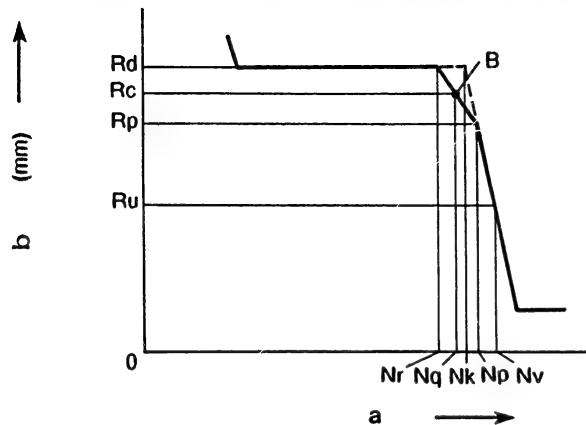

Fig. 177

a = Pump speed (rpm)
b = Control rack position

Torque Spring (When installed)

1. Hold the load control lever in the full load position. Also hold the speed control lever in the maximum speed position.
2. Confirm that governor control starts at a speed of "Nk rpm".
3. Slowly decrease the pump speed from "Nv rpm" and adjust the torque spring capsule (144) so that the control rod is at position "Rc" at a speed of "Nq rpm" (refer to Fig. 178).
4. Confirm that the control rod is at position "Rd" at a pump speed of "Nr rpm", and at position "Rp" at a pump speed of "Np rpm".
5. Also confirm the injection quantity at point B.

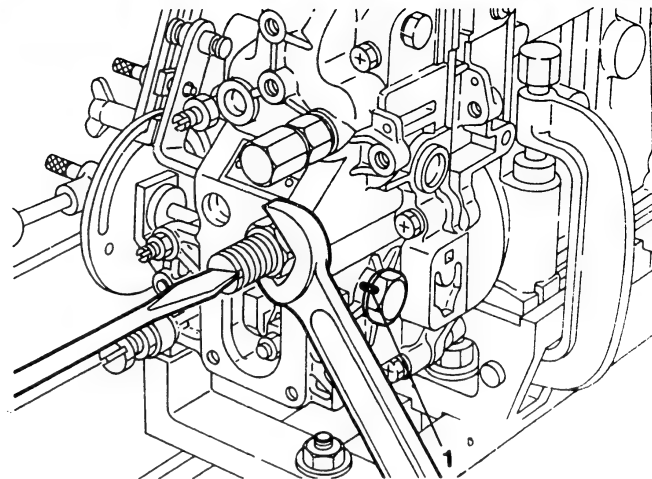

Fig. 178

1 = Paint seal

L8

Adjustment
Governor RFD (K)



L9

Adjustment
Governor RFD (K)



Note: The plug (163) on the side of the governor cover is used to hold the torque lever. Thus, this plug has no relationship to torque spring adjustment and should not be touched.

The plug is coated with paint to draw attention to it at repair shops. If this paint seal should be broken, disassemble the governor, check the torque lever position and then repaint it.

L10

Adjustment

Governor RFD (K)

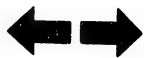

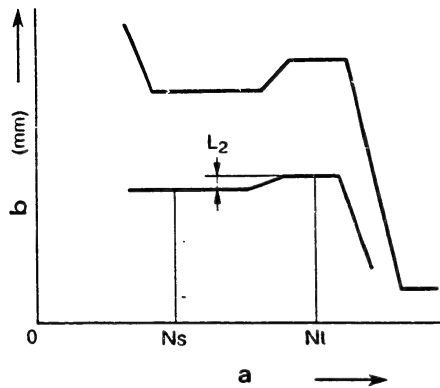

Fig. 179

a = Pump speed (rpm)
b = Control rack position

Torque Control Stroke Confirmation (reduction device only)

1. Drive the pump at a speed of "Ns rpm" and temporarily set the load control lever in the idling position.
2. Next, increase the pump speed and confirm that the torque control stroke is "L₂" at a pump speed of "Nt rpm".

Full Load Injection Quantity Confirmation

1. Hold the load control lever in the full load position.
2. Next, confirm that the fuel injection quantity (point A) under a full load is as specified.
3. If not as specified, adjust using the full load stopper bolt.

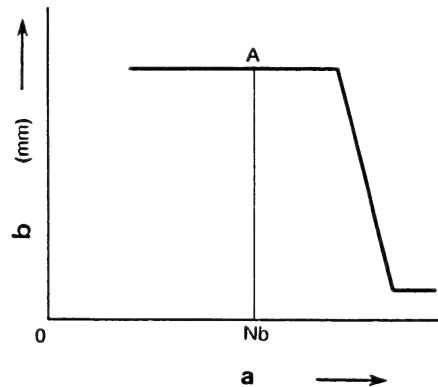

Fig. 180

a = Pump speed (rpm)
b = Control rack position

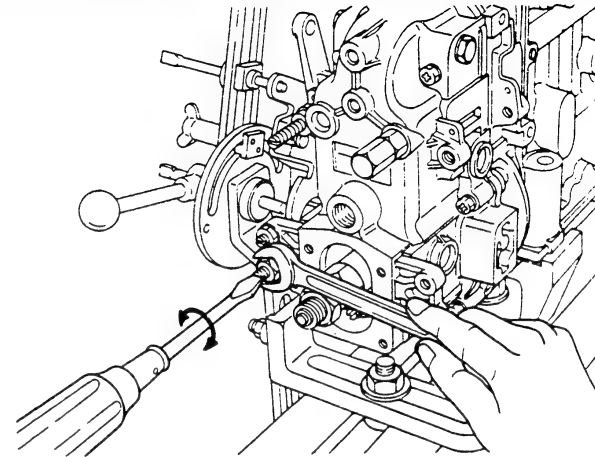

Fig. 181 Full-load stopper bolt readjustment

L11

Adjustment
Governor RFD (K)



L12

Adjustment
Governor RFD (K)



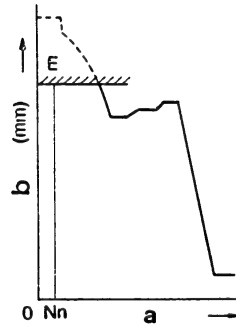
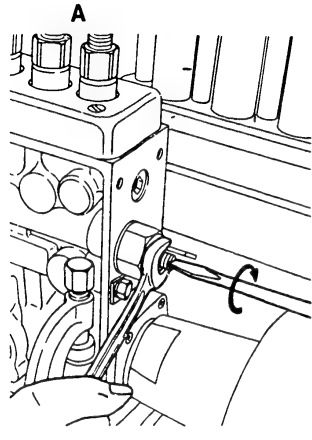

Fig. 182 Screw type

a = Pump speed (rpm)
 b = Control rack position
 A = Screw type

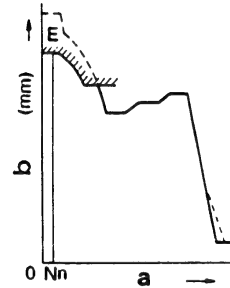
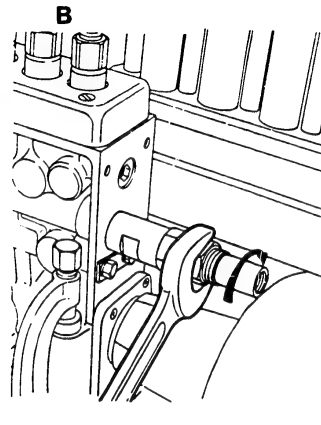

Fig. 183 Spring capsule type

a = Pump speed (rpm)
 b = Control rack position
 B = Spring capsule type

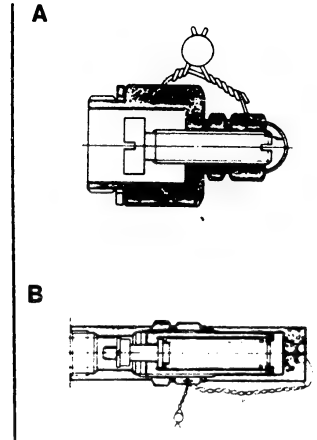

Fig. 184

A = Screw type
 B = Spring capsule type

Smoke Limiter

1. Hold the load control lever in the full load position.
2. Maintain the pump speed at "Nn rpm".
3. Screw in the spring capsule or screw and lock it at point E, where the specified fuel injection quantity may be obtained.

Note: There is no rack limiter when a boost compensator is mounted on the drive side.

L13

Adjustment
 Governor RFD (K)

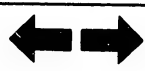

L14

Adjustment
 Governor RFD (K)

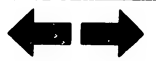

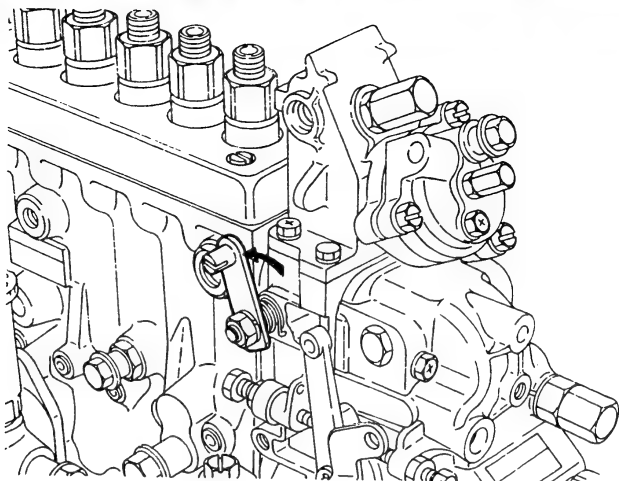

Fig. 185 Confirmation on non-injection zone

Stop Lever Position (when installed)

1. Drive the pump at 800rpm.
2. Move the stopper lever to the stop side and confirm that the control rod enters the non-injection zone.
3. If the control rod does not enter the non-injection zone, check the linkage inside the governor.

L15

Adjustment

Governor RFD (K)



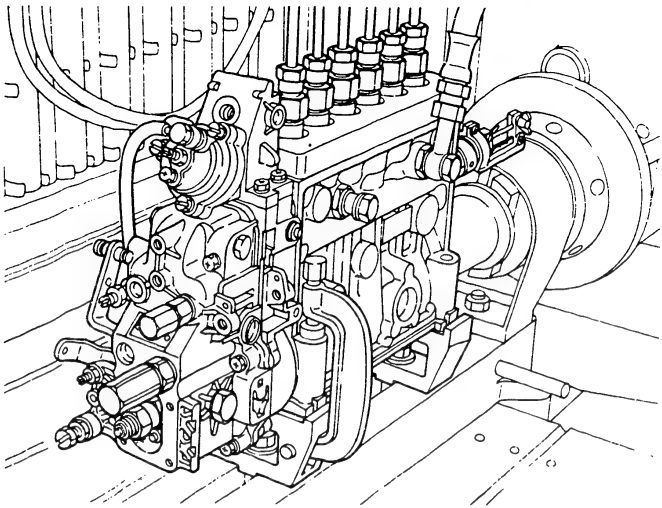

Fig. 186 Mounting the boost compensator

Boost Compensator (when installed)

● Governor side boost compensator

1. Mount the boost compensator assembly on the top of the governor. Remove the rack position adjustment screw. Set the screw (250/62) to the position measured at the time of disassembly.
2. Attach a tube to the eye of the boost pressure intake port and install the air tube.
3. Hold the load control lever in the full load position and drive the pump at a speed of "Nu rpm" (500rpm unless otherwise specified).

L16

Adjustment

Governor RFD (K)



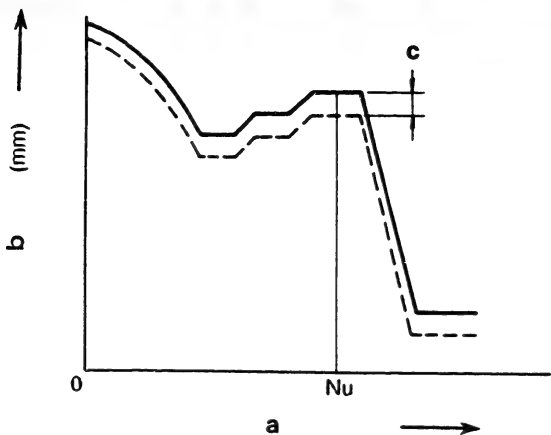

Fig. 187

a = Pump speed (rpm)
 b = Control rack position
 c = B.C.S. stroke

3. Hold the load control lever in the full load position and drive the pump at a speed of "Nu rpm" (500 rpm unless otherwise specified).

L17

Adjustment
 Governor RFD (K)



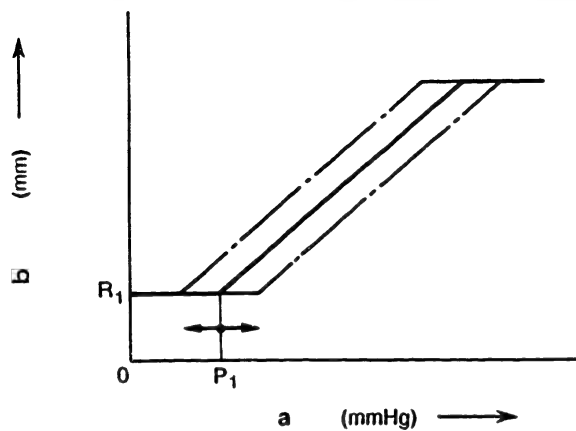

Fig. 188

a = Boost pressure
b = Control rack position

4. Adjust using the adjusting screw (250/62) so that, when the pressure is P_1 , the control rod begins to move in the fuel-increase direction.

Then lock it with the nut (250/63) (refer to Figs. 188 and 189).

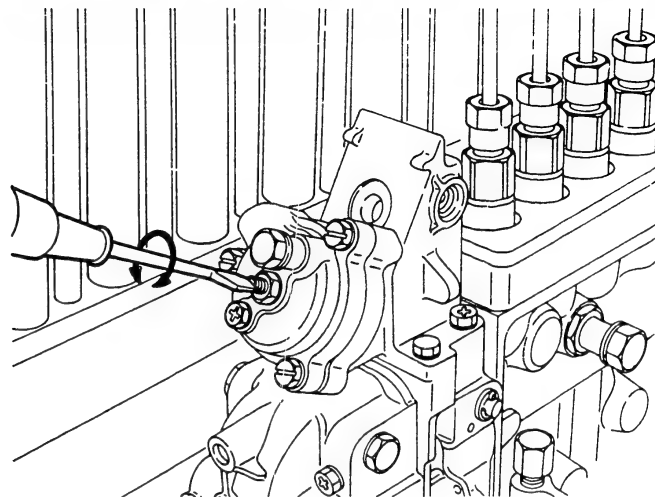
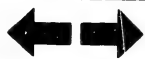

Fig. 189 Adjusting screw (250/62)

L18

Adjustment
Governor RFD (K)



L19

Adjustment
Governor RFD (K)



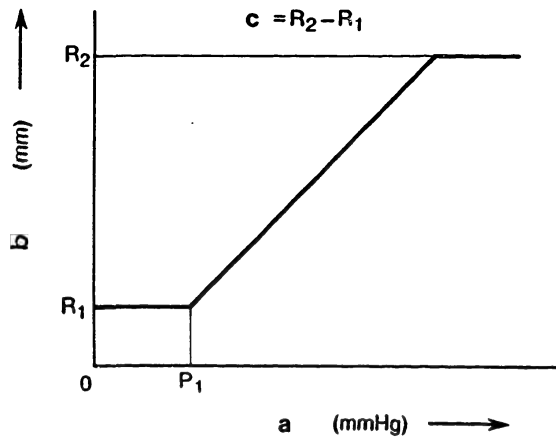

Fig. 190

a = Boost pressure
 b = Control rack position
 c = B.C.S. stroke

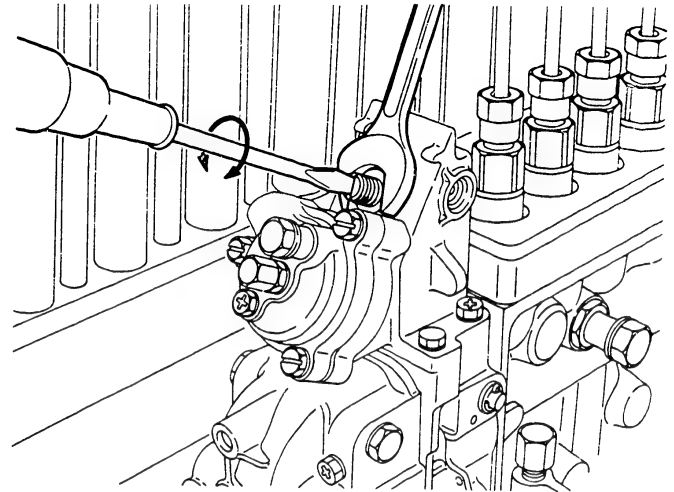

Fig. 191 Adjusting the B.C.S. stroke

5. With no boost pressure applied, adjust the boost compensator stroke to the specified value using the screw (250/91) for rack position adjustment (refer to Fig. 191).

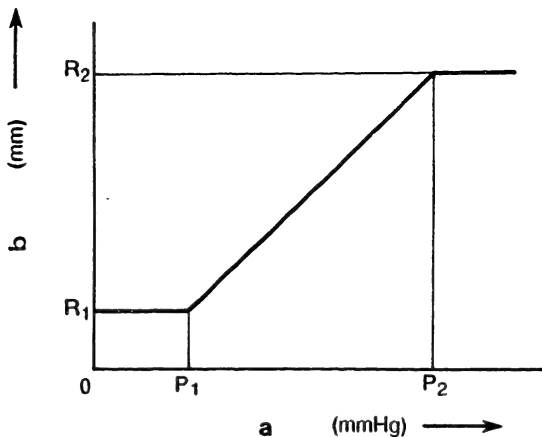

Fig. 192

a = Boost pressure
 b = Control rack position

6. Increase the boost pressure and confirm that the control rod is in position R_1 at P_1 . Also confirm that the control rod is at the R_2 position at P_2 .
7. If not as specified, replace the boost compensator spring.



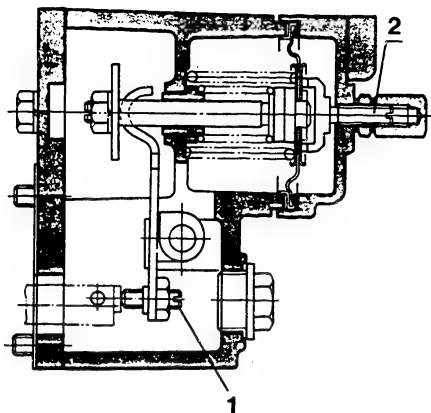

Fig. 193

1 = Screw B

2 = Screw A

● **Drive side boost compensator**

As drive side boost compensator adjustment is the same as that for the governor side boost compensator, only the adjustment points are shown.

Screw A: for boost compensator starting position adjustment

Screw B: for boost compensator stroke adjustment



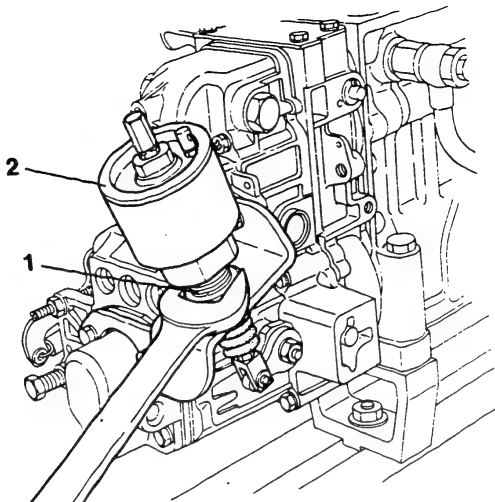

Fig. 194

- 1 = Locknut
- 2 = A.C.S. assembly

Aneroid Compensator (when installed)

1. Temporarily fix the A.C.S. assembly using the locknut.

L24

Adjustment
Governor RFD (K)



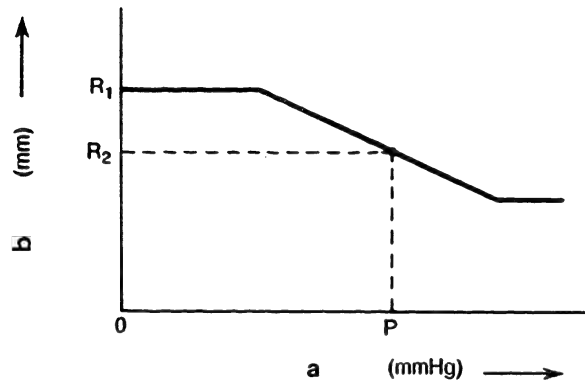

Fig. 195

a = Atmospheric pressure
b = Control rack position

2. Adjust the A.C.S. position so that the control rod is positioned at R_2 when an atmospheric pressure of P mmHg is supplied to the A.C.S. assembly.
Fix the A.C.S. assembly using the locknut.
3. Secure the clevis (16) using the nut (15).
The clevis must be turned at least three times to ensure proper engagement with the pushrod (3).
Should it not sufficiently engage, alter the mounting angle between the lever shaft (205) and the A.C.S. lever, and then repeat adjustment.

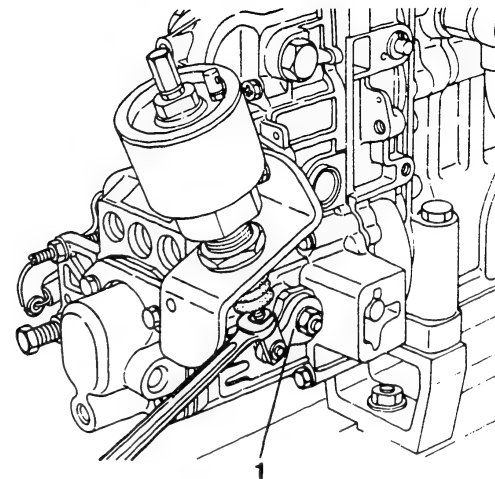
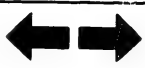

Fig. 196

1 = A.C.S. lever

L25

Adjustment
Governor RFD (K)



L26

Adjustment
Governor RFD (K)



Example of Adjustment Procedure

The following table shows the standard sequence for governor adjustments as shown in the governor performance graphs in Figs. 197-1 to 197-4.

The letters A to D correspond to each governor's performance graph, while the figures show the numerical sequence of adjustment.

As the names of the adjustment procedures are the same as those previously used, refer to them for details (on coord. J20 to L25).

CASE EXAMPLE ADJUSTMENT PROCEDURE	A	B	C	D
Torque control stroke	-	-	(1)~(3)	-
Flyweight lift and full load position	(1)~(4)	(1)~(4)	(4)~(5)	(1)~(4)
Maximum-speed control and speed droop	(5)~(6)	(5)~(6)	(6)~(7)	(5)~(6)
Idling	(7)	(7), (9)~(10)	(8)	(7)
	(9)~(11)	(15)	(10)~(12)	(9)~(11)
Load control lever measurement	(8)	(8)	(9)	(8)
Damper spring	(14)	(11)	(13)	(12)
Stopper bolt	(15)	-	-	-
Positive torque control	-	(12)~(14)	-	-
Negative torque control	-	-	(14)~(16)	-
Minimum speed stopper bolt	(12)	-	-	-
Speed control lever confirmation	(13)	-	-	-
Torque spring	-	-	-	(13)~(15)
Smoke limiter	(16)	(16)	(17)	(16)
Boost compensator	-	(17)~(19)	-	-

L27

Adjustment
Governor RFD (K)

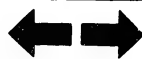

L28

Adjustment
Governor RFD (K)



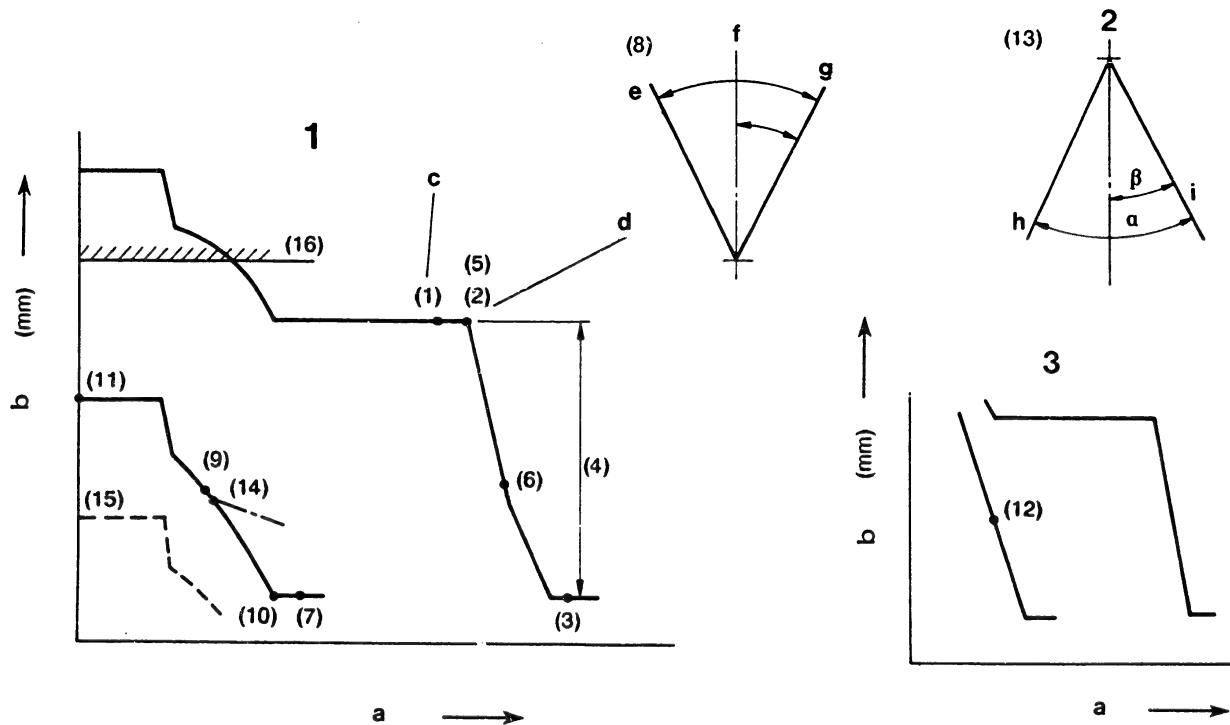

Fig. 197-1

1 = Minimum-maximum speed governor

2 = Speed control lever angle
3 = Variable speed governor

a = Pump speed (rpm)
b = Control rack position
c = Temporary setting
d = Temporary setting
e = Full-load
f = Load control lever angle
g = Idling

a = Pump speed (rpm)
b = Control rack position
h = Minimum speed
i = Maximum speed

(A) Standard RFD Type governor

M1

Adjustment
Governor RFD (K)

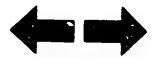

M2

Adjustment
Governor RFD (K)



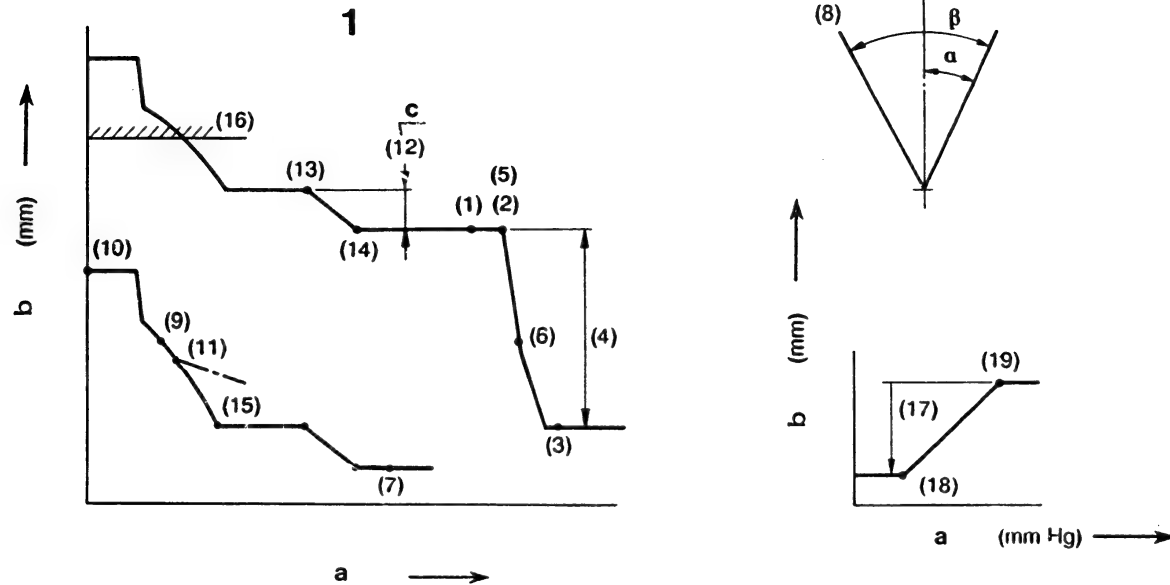

Fig. 197-2

1 = Minimum-maximum speed governor

a = Pump speed (rpm)
 b = Control rack position
 c = Torque control stroke adjustment
 (using spring capsule)

a = Boost pressure
 b = Control rack position
 c = Load control lever angle

(B) RFD Type governor with positive torque control

M3

Adjustment
 Governor RFD (K)

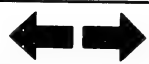

M4

Adjustment
 Governor RFD (K)

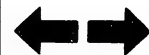

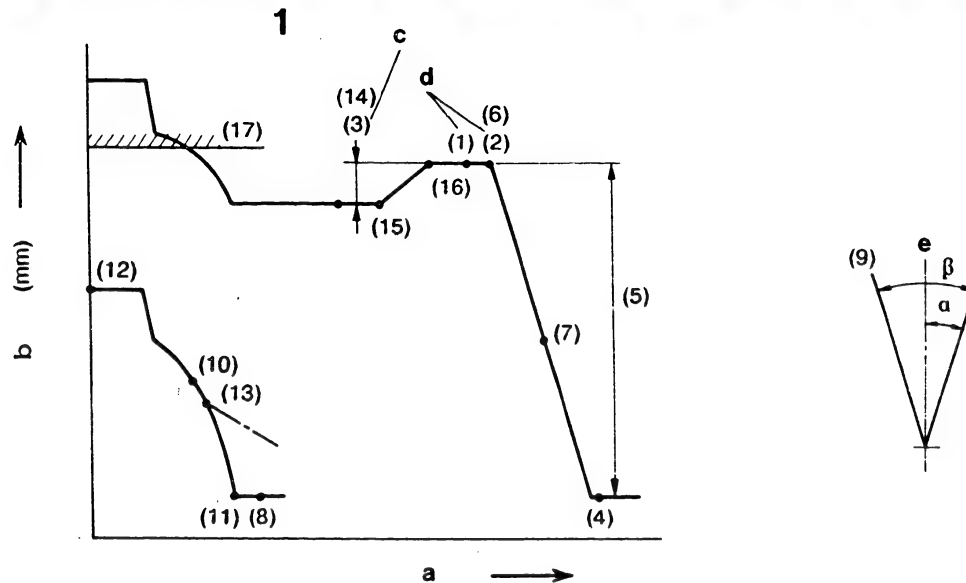

Fig. 197-3

1 = Minimum-maximum speed governor

a = Pump speed (rpm)

b = Control rack position

c = Stroke adjustment (using adjusting screw)

d = Temporary setting

e = Load control lever angle

(C) RFD-K Type governor

M5

Adjustment
Governor RFD (K)



M6

Adjustment
Governor RFD (K)

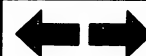

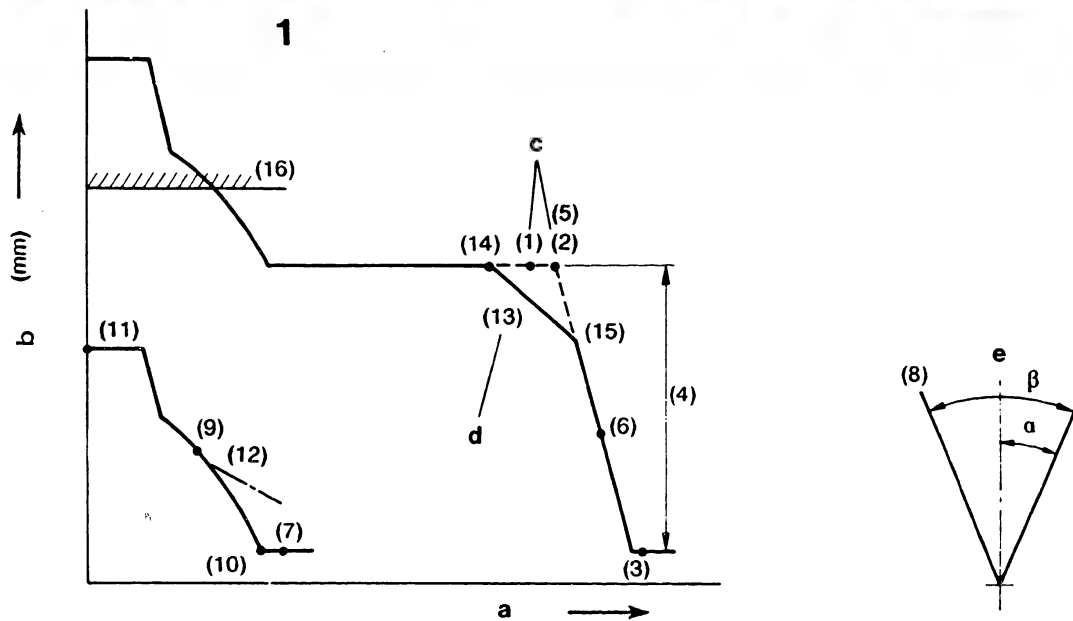

Fig. 197-4

1 = Minimum-maximum speed governor

- a = Pump speed (rpm)
- b = Control rack position
- c = Temporary setting
- d = Torque spring adjustment
- e = Load control lever angle

(D) RFD Type governor with torque spring

M7	Adjustment	↔
	Governor RFD (K)	

M8	Adjustment	←
	Governor RFD (K)	

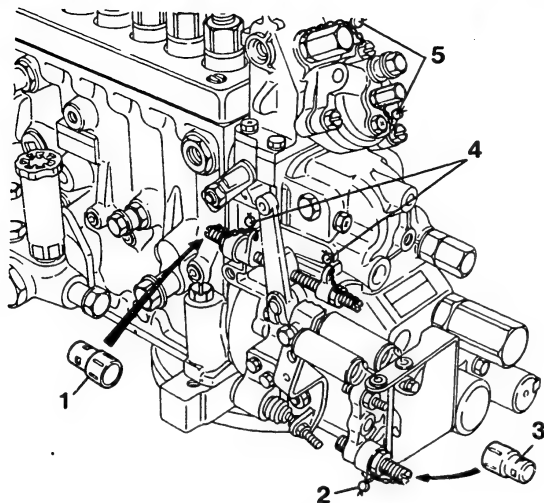

Fig. 198

- 1 = Cap type seal
- 2 = Wire type seal
- 3 = Cap type seal
- 4 = Wire type seal
- 5 = Wire type seal

HANDLING

Seals

The various adjusting screws of the governor are adjusted and set using a pump test stand on an engine test bench. Therefore, never change the settings of the adjusting screws unless these same facilities are available. Changing the adjusting screw positions will prevent the engine from delivering the specified performance.

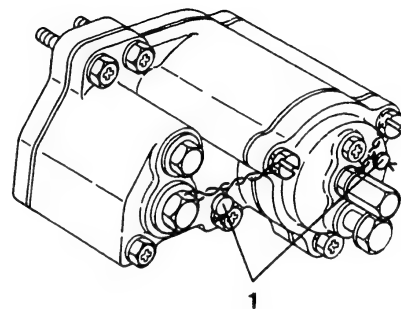

Fig. 199

- 1 = Seal

M9

Handling
Governor RFD (K)



M10

Handling
Governor RFD (K)



Handling (cont'd)

When new shipments are received from the engine manufacturer or adjustments are made using a tester, all externally exposed adjusting screws on governors and additional devices are sealed to indicate that they have been adjusted.

Never remove these seals except when making adjustments. There are two types of seals: the wire type and the cap type.

Lubricating oil

Forced lubrication systems which lubricate by circulating engine oil inside the injection pump cam chamber and governor chamber are normally used. Thus, there is no need for separate lubricating oil pipes for injection pumps. Engine oil should, however, be inspected and replaced using the procedures specified by the manufacturer.

Injection pumps are precision devices and oil sludge, etc., can have considerable adverse influence on the service life of the various parts.



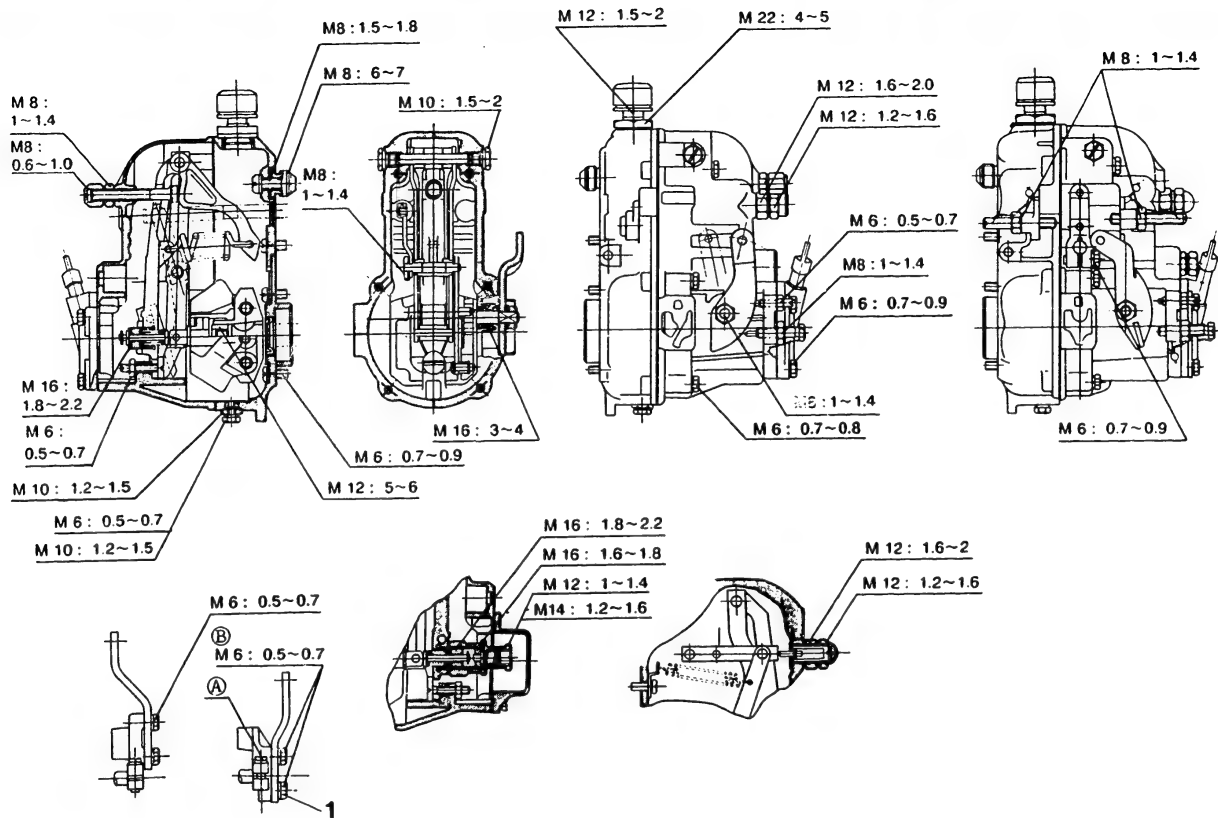

Fig. 200

Unit: kgm

1 = Tighten bolt (B) after tightening bolt (A)

TIGHTENING TORQUES

M12	Tightening torques	➔
	Governor RFD (K)	

M13	Tightening torques	➔
	Governor RFD (K)	

EXPLANATION OF PART NUMBERS

Code Number

1 0 5 4 8 7 - 0 0 1 0

↑ ↑ ↑ ↑
(1) (2) (3) (4)

(1) assembly and manufacturing number

(2) governor mounting position

8 right side mounting

9 left side mounting

(3) size and type

0 A type pump

1 A type pump with boost compensator

2 A type pump with torque control spring and/or torque spring

7 P type pump

8 P type pump with torque control spring and/or torque spring

(4) specific number

Bosch Type Number

NP - EP / RFD 200 / 1350 A F7 A D L
(1) (2) (3) (4) (5) (6) (7) (8) (9) (10) (11)

M14

Explanation of part numbers

Governor RFD (K)



M15

Explanation of part numbers

Governor RFD (K)



Explanation of part numbers (cont' d)

- (1) manufactured by ZEXEL
- (2) injection pump accessory
- (3) RFD Type governor
- (4) controlled minimum speed (pump speed)
- (5) control type
 - / minimum/maximum speed type governor
 - ~ variable-speed type governor
- (6) controlled maximum speed control (pump speed)
- (7) pump size
- (8) design number
- (9) design number
- (10) additional devices
 - 0 none
 - A ACS device
 - D positive torque control
 - P negative torque control
 - L BCS device
 - S stopping device
- (11) mounting position
 - L left side mounting
 - R right side mounting

M16

Explanation of part numbers
Governor RFD (K)



M17

Explanation of part numbers
Governor RFD (K)



RFD-A, -B, AND -C TYPE GOVERNORS

The following three types of RFD governors are manufactured for use with PE.A, .AD and .P type injection pumps. Their main differences are described below.

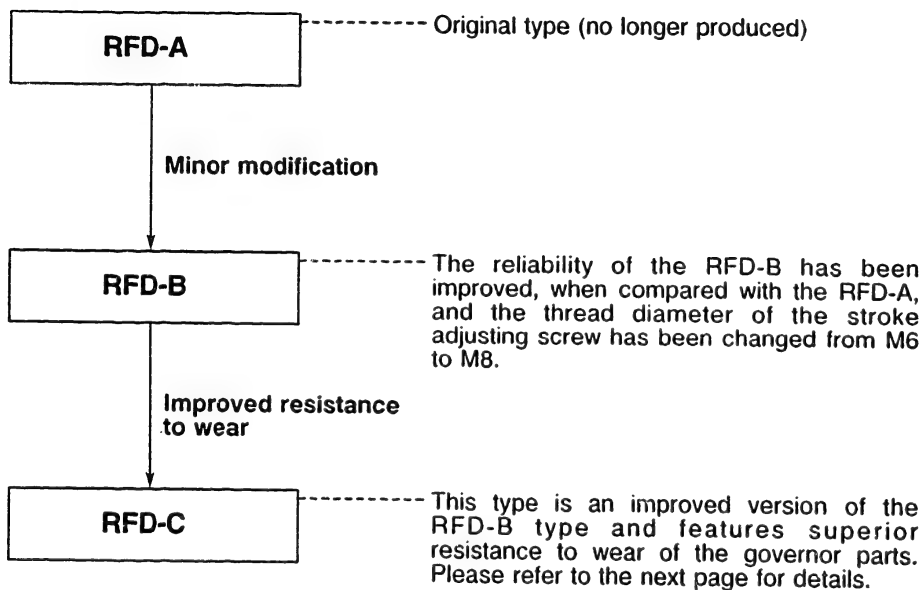

In addition to the above three types, an RFD-D type governor is also manufactured for use solely with the PE.P Type pump.

This governor has heavier flyweights than the above three, and increased control in the low-speed range. Accompanying this increased control is a further improvement in the governor parts' resistance to wear.

M18

Type governors
Governor RFD (K)



M19

Type governors
Governor RFD (K)



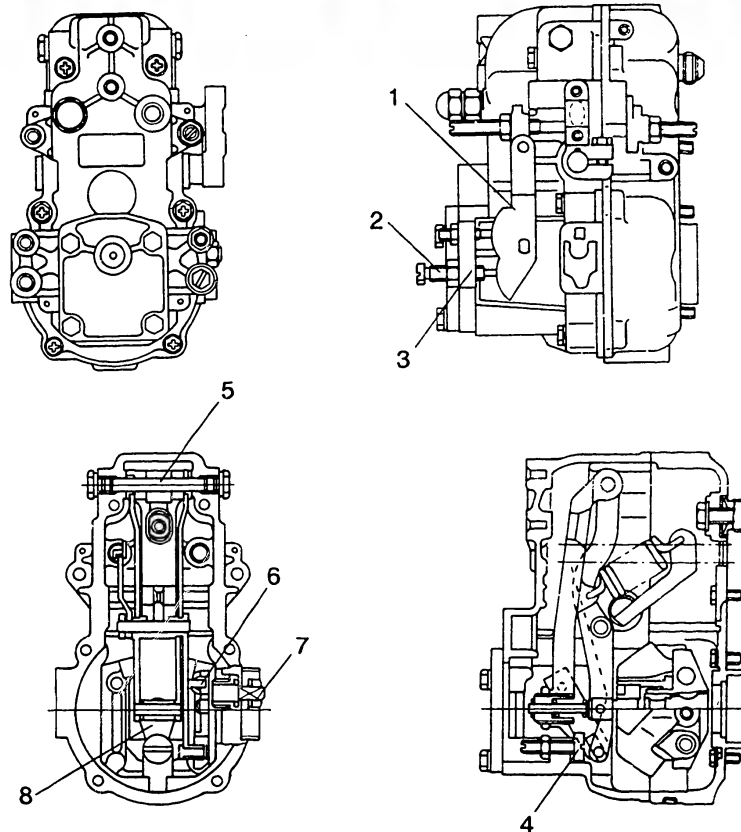

Fig. 201

Differences between RFD-B and C type governors

Figure 201 shows cross-sectional views of the RFD-B Type governor.

The key numbers in the above figure indicate the positions where modifications have been made.

For details of the modifications, refer to the following table.

The key numbers in the table correspond to the key numbers in the above figure.

M20

Type governors

Governor RFD (K)

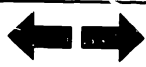

M21

Type governors

Governor RFD (K)



RFD-B

1

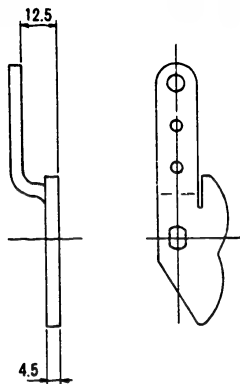

RFD-C

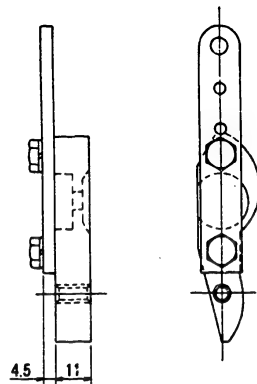

RFD-B

3

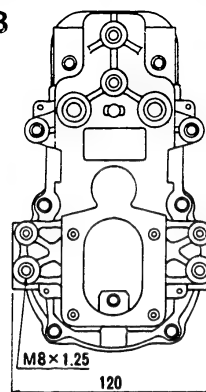

RFD-C

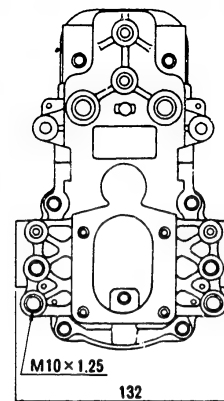

2

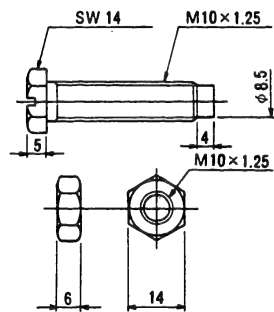
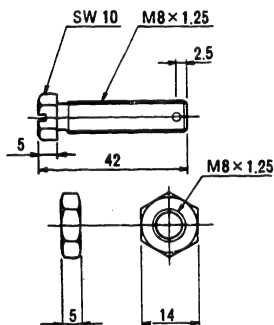

No.	Modification
1	Load control lever
2	Full load stopper bolt and nut
3	Installation position of the governor cover's full load stopper bolt

M22

Type governors
Governor RFD (K)

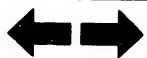

M23

Type governors
Governor RFD (K)



RFD-B

RFD-C

RFD-B

RFD-C

4

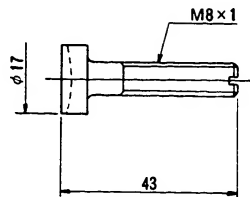

5

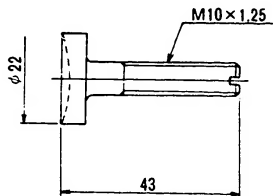

7

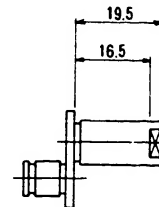
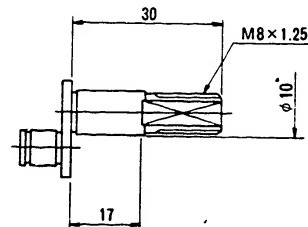

1

2

5

5

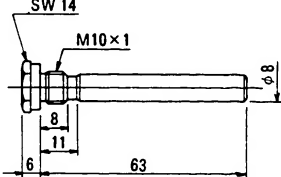
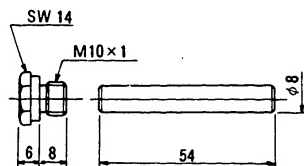

8

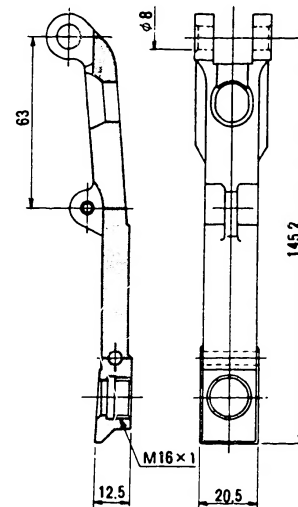
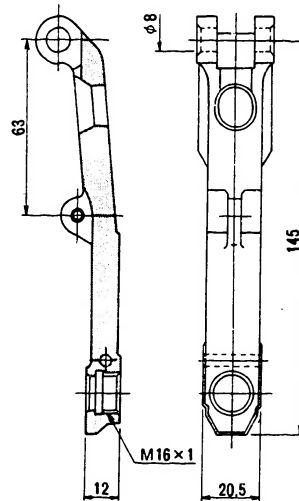

6

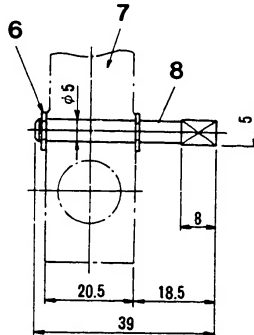
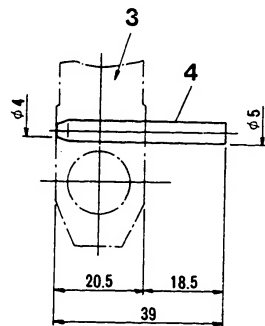

No.	Modification
4	Stroke adjusting screw
5	Tension lever shaft
6	Supporting lever pin
7	Load control lever shaft
8	Lower end of the tension lever

- 1 = Plug
- 2 = Pin
- 3 = Tension lever
- 4 = Pin

- 5 = Plug and pin assembly
- 6 = Snap ring
- 7 = Tension lever
- 8 = Pin

M24

Type governors
Governor RFD (K)



M25

Type governors
Governor RFD (K)



CONTENTS

	Coordinates
FEATURES	A 2
PRINCIPLE OF OPERATION	A 8
Spring and Weight	A 8
Balance Between Spring and Centrifugal Force	A 9
Fuel Injection Quantity Adjustment Operation	A 11
RFD Type Governor	A 18
RFD-K Type Governor	A 23
The Necessity for Positive Torque Control	A 25
The Necessity for Negative Torque Control	B 1
CONSTRUCTION	B 4
RFD Type Governor	B 4
RFD-K Type Governor	B 16
OPERATION	B 20
RFD Type Governor	B 20
RFD-K Type Governor	C 10
ADDITIONAL DEVICES	C 18
Boost Compensator (B.C.S.)	C 18
Aneroid Compensator (A.C.S.)	D 4
Torque Spring	D 17
Stopping Device	D 25
Reduction Device (installed on RFD-K governor)	E 1
SPECIAL TOOLS	E 24
Special Tools for Disassembly and Reassembly	E 24
Special Tools for Adjustment	F 11

N23

Contents
Governor RFD (K)



N24

Contents
Governor RFD (K)



Contents (cont' d)

	Coordinates
EXPLODED VIEWS	F 25
DISASSEMBLY	G 1
Preparation	G 2
Governor Side Boost Compensator Disassembly	G 10
Governor Cover Disassembly	G 19
Governor Housing Disassembly	H 16
INSPECTION	H 25
REASSEMBLY	J 11
ADJUSTMENT	J 20
Preparation	J 26
Setting the Control Rod's Zero Position	K 1
Torque Control Stroke (RFD-K Type only)	K 5
Flyweight Lift and Full Load Position	K 8
Maximum-Speed Control and Speed Droop	K 12
Idling	K 15
Load Control Lever Angle Measurement	K 17
Damper Spring	K 19
Stopper Bolt	K 21
Positive Torque Control (When installed)	K 23
Negative Torque Control (RFD-K Type only)	K 27
Minimum-Speed Stopper Bolt	L 5
Speed Control Lever Angle Confirmation	L 7
Torque Spring (When installed)	L 8
Torque Control Stroke Confirmation (Reduction device only)	L 11

Contents (cont' d)

Coordinates

ADJUSTMENT (cont' d)

Full Load Injection Quantity Confirmation	L 11
Smoke Limiter	L 13
Stop Lever Position (When installed)	L 15
Boost Compensator (When installed)	L 16
Aneroid Compensator (When installed)	L 24
Example of Adjustment Procedure	L 27
HANDLING	M 9
Seals	M 9
Lubricating Oil	M 11
TIGHTENING TORQUES	M 12
EXPLANATION OF PART NUMBERS	M 14
RFD-A, -B, AND -C TYPE GOVERNORS	M 18